

MARCO
COLLECTION

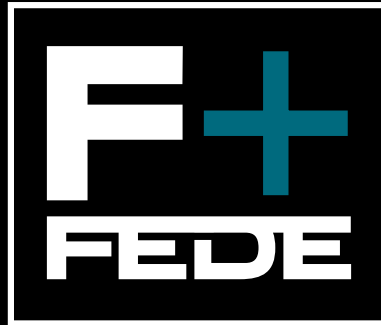

MARCO COLLECTION

"Simplicity is the
ultimate sophistication"

Leonardo da Vinci



Index

INTRODUCTION	3	AUDIO RECEIVER	44
SWITCHES		SOCKETS	46
Switch with Keys	17	TV/SAT SOCKET OUTLETS	50
Toggle Switch	23	MULTIMEDIA CONNECTORS	53
Rotary Switch	27	THERMOSTATS	56
Infrared Light Switch	30	OTHER ELECTRICAL MECHANISMS	58
Switch for Blinds	31	INSTALLATION ACCESORIES	60
DIMMERS		INSTALLATION EXAMPLES	62
Touch	32	TECHNICAL DATA	64
Rotary	33		
Push Button	35		
NIGHT LIGHT INDICATOR	38		
NEW USB CHARGER	40		
NEW HOTEL CARD SWITCH	42		

Introduction

New MARCO collection

MARCO is the new contemporary metal collection by FEDE. Based on the purest concept of a switch frame, it includes modern finishes with a velvety feel.

You'll understand what we mean when you may have MARCO in your hands: it's as smooth as silk. Enjoy our new and incredibly touchable design.

The latest TREND, with an elegance that's both modern and classic. This is a NEW FRENCHIFIED and TRANSITIONAL STYLE, which allows for a wide-range of decoration possibilities, all the while fitting perfectly in white, black, moka, green olive or red wine.

We invite you to combine our new frames with all of FEDE's electrical mechanisms. You'll discover intriguing innovations that complement our extensive range, like dimmers and toggle switches, both metal and with a FACTORY touch, created for LOFT-type spaces.

Think metal and choose MARCO, the ideal collection to change the switches in your home. You will be simply amazed...

Nouvelle collection MARCO

MARCO est la nouvelle collection métallique et totalement contemporaine créée par FEDE. Basée sur un concept épuré d'interrupteur aux finitions très modernes et au touché de velours. Vous comprendrez ce que nous disons lorsque vous tiendrez la plaque décorative MARCO entre vos mains: lisse comme de la soie. Une sensation incroyable pour profiter au maximum de notre nouvelle conception. La dernière TENDANCE, si moderne mais tout aussi classique à la fois pour son élégance. Nous vous parlons d'un NOUVEAU STYLE FRANÇAIS et TRANSITIONNEL qui nous inspire et qui s'intègre parfaitement avec la décoration... En Blanc, noir, moka, olivier ou bordeaux.

Nous vous invitons à combiner nos nouvelles plaques décoratives MARCO avec l'appareillage électrique de FEDE. Vous découvrirez de nouveaux développements très intéressants qui complètent notre large gamme tels que le régulateur de lumière et l'interrupteur à bascule, les deux métalliques, avec une inspiration FACTORY, ils ont été conçus pour des espaces de type LOFT. Métallisez-vous et choisissez MARCO, c'est tout simplement la collection idéale pour changer les interrupteurs de votre maison. Vous en serez surpris...

Nuova collezione MARCO

MARCO è la nuova collezione metallica e totalmente contemporanea creata da FEDE. Basata sul concetto di covers dalle finiture ultramoderne e da una morbida sensazione al tatto.

Ne comprenderete il significato solo quando terrete un interruttore MARCO nelle vostre mani: morbido come seta. Una sensazione incredibile che vi permetterà di godere appieno della nostra nuova creazione. La ultima TENDENZA, moderna e al tempo stesso classica grazie alla sua eleganza.

Stiamo parlando di un NUOVO STILE FRANCESIZZATO E TRANSIZIONALE che lascia molto spazio decorativo.. in bianco, nero, caffè, verde oliva e rosso vino. Ti invitiamo a combinare i nuovi MARCO con tutti i diversi meccanismi elettrici FEDE. Scoprirai novità molto interessanti che completano la nostra vasta gamma, come ad esempio i regolatori di luce e l'interruttore a levetta, entrambi metallici, con un tocco di FACTORY, creati per spazi tipo LOFT. Scegli MARCO, la collezione ideale per cambiare gli interruttori di casa tua. Ti sorprenderà...

Nueva colección MARCO

MARCO es la nueva colección metálica totalmente contemporánea creada por FEDE. Basada en el concepto más puro de un MARCO de interruptor con acabados muy actuales y de tacto aterciopelado.

Comprenderás lo que decimos cuando tengas el MARCO en tus manos: es suave como la seda. Una sensación increíble para que disfrutes al máximo de nuestro nuevo diseño.

La última TENDENCIA, moderna sí, pero a la vez clásica por su elegancia. Estamos hablando de un NUEVO ESTILO AFRANCESADO y TRANSICIONAL que nos da mucho juego decorativo y encaja perfectamente en blanco, negro, moka, verde oliva o burdeos.

Te invitamos a combinar los nuevos MARCOS con todos los mecanismos eléctricos de FEDE. Descubrirás novedades muy interesantes que complementan nuestra extensa gama como el regulador de luz y el interruptor de palanca, ambos metálicos, con un toque FACTORY, creados para espacios tipo LOFT.

Metalízate y elige MARCO, es simplemente la colección ideal para cambiar los interruptores de tu casa. Te sorprenderá...

Neue MARCO kollektion

MARCO ist die neue metallische Kollektion vollkommen zeitgenössisch von Fede entworfen. Sie basiert auf dem reinsten Konzept eines Schalterahmen MARCO (Rahmen) mit sehr aktuellen Oberflächen und einem sanften Touch. Sie werden verstehen, was wir meinen, wenn Sie MARCO in Ihren Händen halten: es ist seideweich. Ein unglaubliches Gefühl, wobei Sie das Maximum unseres neuen Designs genießen. Die letzte TENDENZ, schon modern, aber gleichzeitig auch klassisch durch seine Eleganz. Wir sprechen von einem NEUEN ÜBERGANGS-STIL mit FRANZÖSISCHEM HAUCH, der uns viel Spielraum zum Dekorieren gibt, und ausserst gut zu Weiß, Schwarz, Olivgrün, Weinrot oder Mokka passt. Wir laden Sie ein, den neuen MARCO mit allen elektrischen Mechanismen von FEDE zu kombinieren. Sie werden sehr interessante Neuheiten entdecken, die unsere umfangreiche Auswahl ergänzen. Wie z.B. die Dimmer und Schaltebel, beide metallisch, und mit einem FACTORY-Touch, sind wie geschaffen für Räume wie LOFTS. Metallisieren Sie sich und wählen Sie MARCO, es ist die ideale Kollektion, um Ihre Lichtschalter zuhause aufzufrischen. Sie werden begeistert sein ...

TWO DIFFERENT FRAME SIZES

For a total contemporaneous decoration we have designed two sizes that will fit perfectly in your Home Interior.
Which is your choice:
Rectangular or Square?

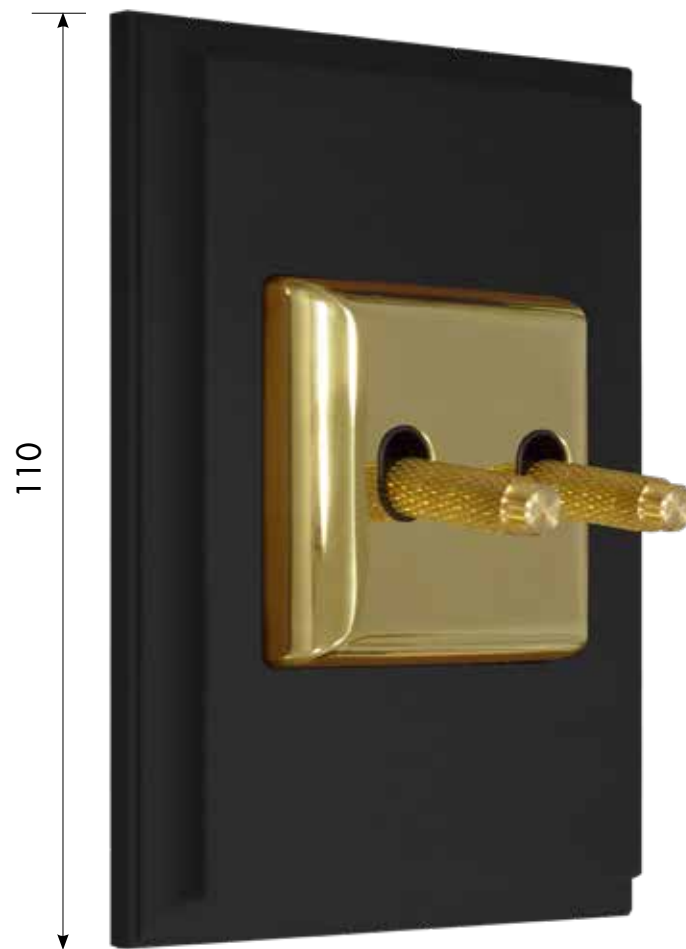

RECTANGULAR
110 x 85 mm



SQUARE
85 x 85 mm

MARCO COLLECTION



MARCO
COLLECTION

SOFT TOUCH

The exclusive **SOFT TOUCH**
by **FEDE**.

How metal could be that
smooth?

Discover **MARCO** collection





THE LATEST TREND

With an elegance that's
both modern and classic.
A FACTORY touch, created
for loft-type spaces.



STATE-OF-THE-ART
ELECTRICAL
MECHANISMS

Like our new dimmer and toggle
switches, both METAL.



MARCO
COLLECTION





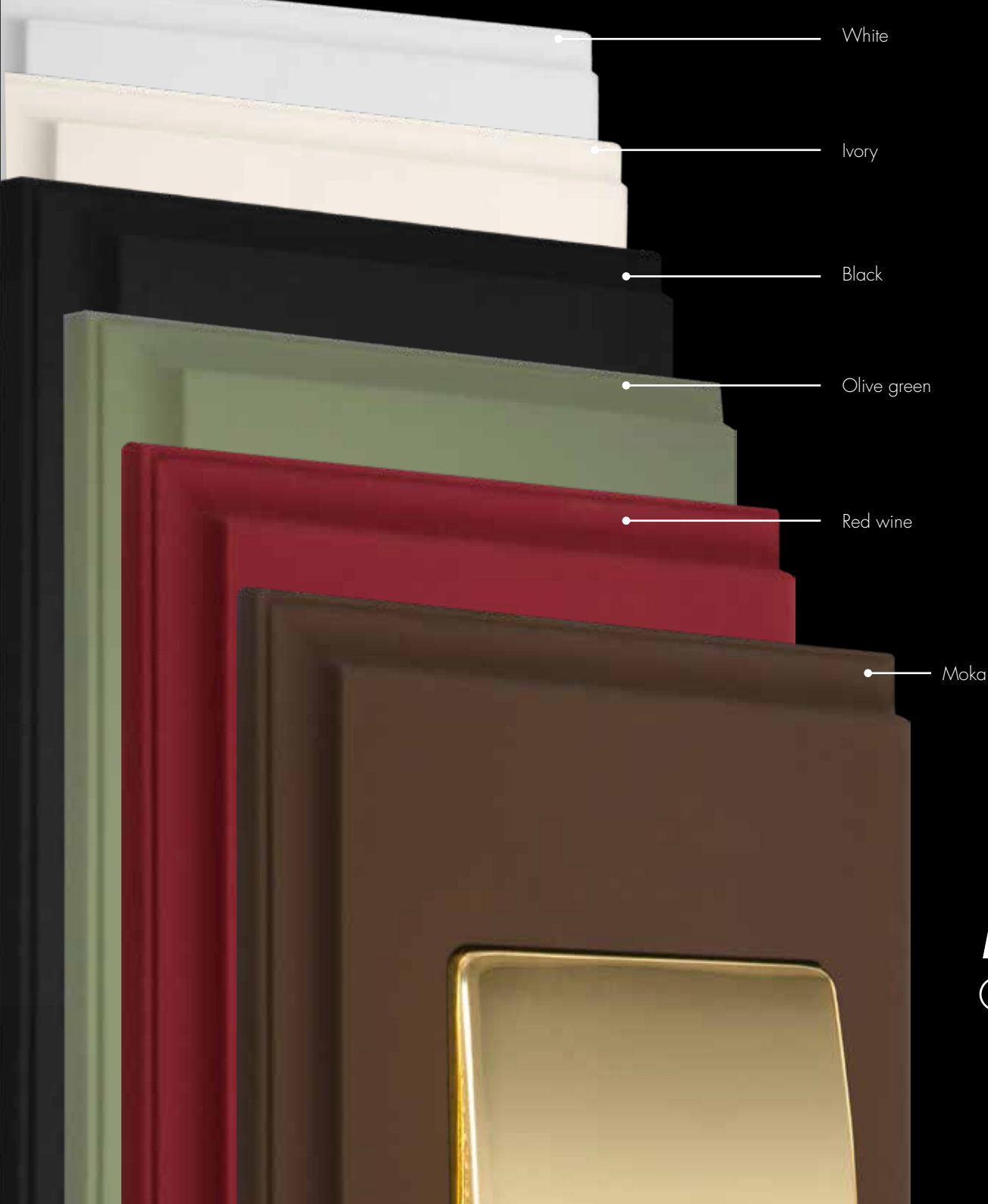

White

Ivory

Black

Olive green

Red wine

Moka

SOPHISTICATED FINISHES & COMBINATIONS

White, beige, black, moka, green
olive & red wine.

All them could be mixed with gold
& chrome electrical mechanisms.



MARCO COLLECTION

Design, Evolution & Revolution

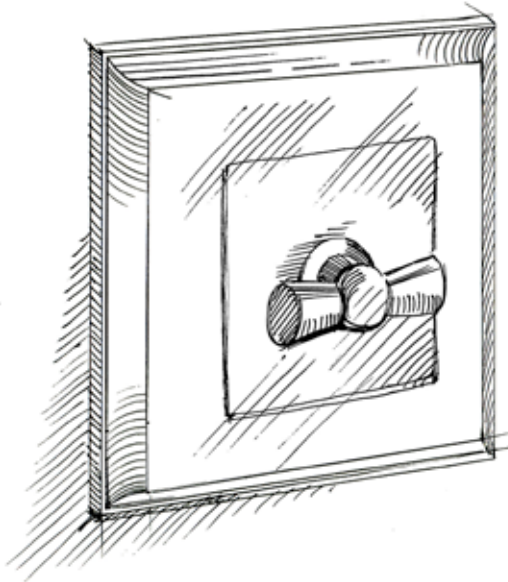
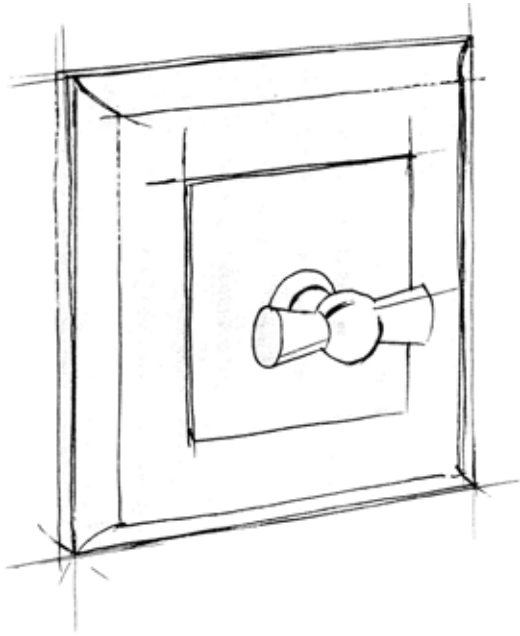

FROM
CLASSIC
TO
MODERN!
How is it possible?
FEDE is the
SWITCH & LIGHT
tailor, creating
timeless styles
that will last forever.

MARCO
COLLECTION

Design, Evolution & Revolution

*ITEMS' REAL SIZE ARE SHOWN IN THE IMAGES



REAL SHAPE &
ALL IN METAL!

What do you prefer for your project?

- 1- Press switch with METAL key and frame.
- 2- METAL toggle switch with METAL frame.
- 3- METAL rotary switch with METAL frame.
- 4- METAL rotary dimmer with METAL frame.

SLIM & CLASSY!

Maximum Flexibility

The same switch mechanisms are used in both toggle switches and switches with keys. Thanks to our system's versatility, you can always easily change the design of already installed switches without performing complicated electrical work for their assembly.

For two-key switches, both mechanisms are installed in the fixing support. Different types of switch mechanisms can be combined, such as a simple switch and a two-way switch.

For single key switches, the mechanism is installed in the central part of the fixing support.



Modular System

The modular structure of the MARCO collection guarantees a maximum flexibility when being installed. Our wide range of electronic mechanisms allows for an optimal technical solution.



Most items, with the exception of complex electronic devices, are supplied disassembled without keys or front plates, i. e., any decisions regarding appearance can be taken during the project's final stage.

All system elements are connected through a clip system to ensure easy installation.

Choice of Frame (Switch Plate)

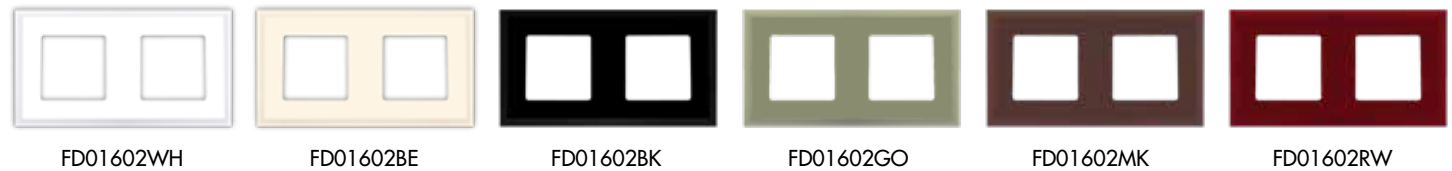
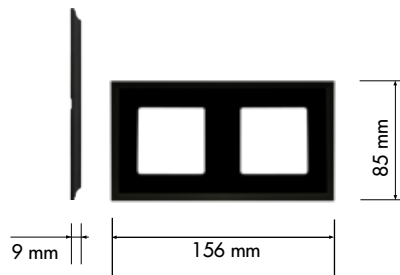
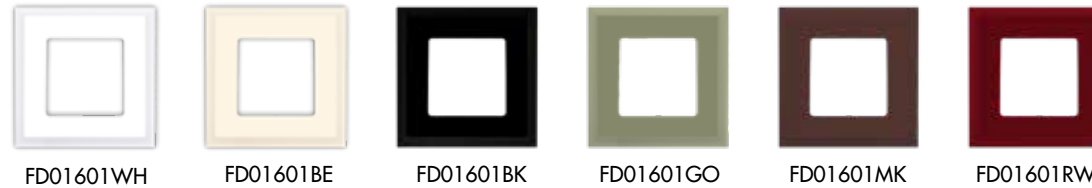
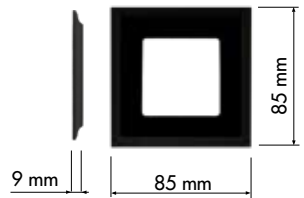
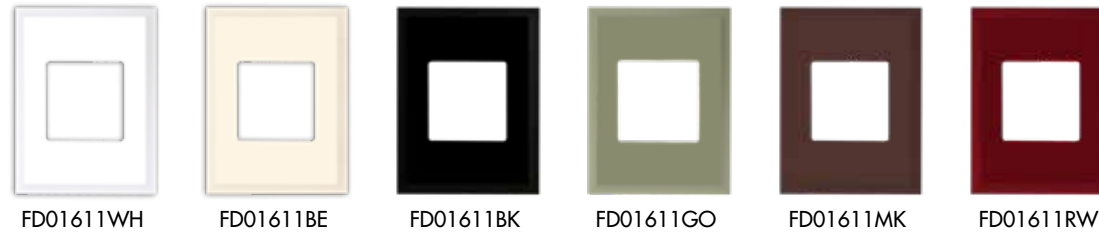
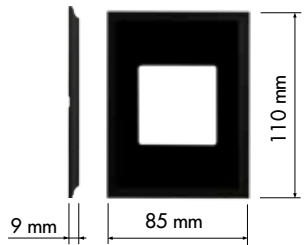

For other finishes, please consult our Sales Department.

MARCO
COLLECTION

Choice of Frame (Switch Plate)

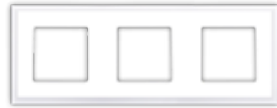
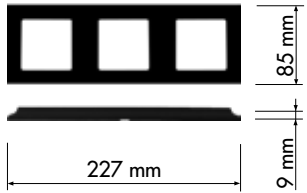

FD01603WH



FD01603BE



FD01603BK



FD01603GO



FD01603MK



FD01603RW

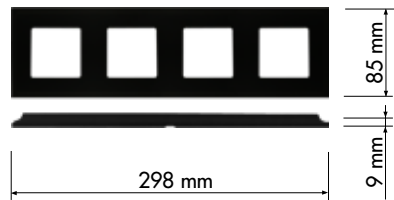

FD01604WH



FD01604BE



FD01604BK



FD01604GO



FD01604MK



FD01604RW

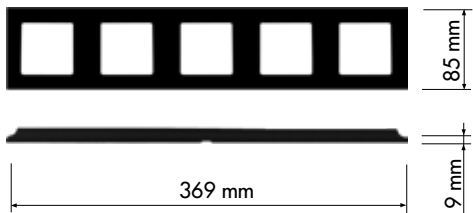

FD01605WH



FD01605BE



FD01605BK



FD01605GO



FD01605MK



FD01605RW

For other finishes, please consult our Sales Department.



A MODULAR & UNIVERSAL SYSTEM

MAXIMUM VERSATILITY

In the Marco collection, we offer a wide range of decorative frames with the possibility to install up to five mechanisms.

Our decorative frames are universal and may be installed in both horizontal and vertical positions.





Switch with Brass Keys

For those who appreciate the real touch of metal, we have designed keys in real brass with a high-quality electroplated surface.

The combination of the shine of the brass surface and the matte finish of the decorative frames results in true elegance and sophistication.

BRASS KEYS/TOUCHES EN LAITON/SCOCHE IN OTTONE/TECLAS DE LATÓN/
METALL-SCHLÜSSEL

PLASTIC WIDE KEYS/TOUCHES LARGES EN PLASTIQUE/TASTI LARGHI IN PLASTICA/
TECLAS ANCHAS DE PLÁSTICO/BREITE KUNSTSTOFFTASTEN



PLASTIC NARROW KEYS/TOUCHES ÉTROITES EN PLASTIQUE/TASTI STRETTI IN PLASTICA/
TECLAS ESTRECHAS DE PLÁSTICO/SCHMALE KUNSTSTOFFSCHLÜSSEL

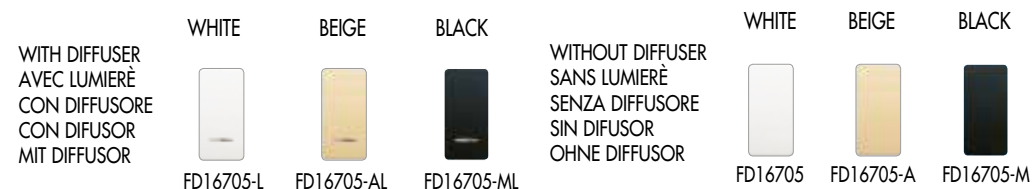

LIGHT INDICATORS/VOYANT/INDICATORE LUMINOSO/SEÑALIZADOR LUMINOSO/LEUCHTANZEIGE



FD21139-1
Blue LED indicator for DP switches and intermediate switches 230 V~ 1mA
Indicateur LED bleu pour interrupteurs DP et interrupteurs intermédiaires 230 V - 1mA
Indicatore LED blu per interruttori DP e meccanismi incrociati 230 V - 1mA
Señalizador de LED azul para interruptores bipolares y cruzamiento 230 V~ 1mA
Blaue LED-Anzeige für DP Ausschalter und Kreuzschalter 230V ~ 1mA



FD21139-2
Blue LED indicator for SP switches, push-buttons and two-way switches 230 V~ 1mA
Indicateur LED bleu pour interrupteurs SP, bouton-poussoir et interrupteurs va et vient 230 V - 1mA
Indicatore LED blu per interruttori SP, pulsanti e commutatori 230 V - 1mA
Señalizador de LED azul para interruptores unipolares, pulsadores y conmutadores. 230 V~ 1mA
Blaue LED-Anzeige für SP Ausschalter, Taster und Wechselschalter 230V ~ 1mA

ADDITIONAL RESISTANCE / RÉSISTANCE SUPPLÉMENTAIRE / RESISTENCIA ADICIONAL

FD3139
Tensión: Máx. 250V
500 NF
Resistencia: 1MΩ
N



When using a switch with LED, the additional resistance stops LED lights from flickering when switched off, while saving energy. The additional resistance installed eliminates the capacitor's leakage currents that cause lights to flicker when the power is switched off.

Permite eliminar el parpadeo de las lámparas LED con un ahorro de energía en estado apagado, al utilizar un interruptor con iluminación. La resistencia adicional instalada en la cadena elimina las corrientes de fuga que cargan el condensador y llevan al parpadeo de las lámparas después de apagar la alimentación eléctrica.

Permet d'éliminer le clignotement des lampes LED pour une économie d'énergie. En mise sous tension, lors de l'utilisation d'un interrupteur d'éclairage. La résistance supplémentaire installé dans la chaîne élimine les courants de fuite que produit le condensateur et qui conduit au clignotement des lampes une fois la mise hors tension de l'alimentation électrique.

UNIPOLAR SWITCH
INTERRUPTEUR UNIPOLAIRE
INTERRUPTORE UNIPOLARE
INTERRUPTOR UNIPOLAR
UNIPOLARSCHALTER



FD16505
One-way SP switch/Interrupteur standard SP/Interruttore semplice/
Interruptor simple/SP Ausschalter

FD16506
Two-way SP switch/Interrupteur va et vient SP/Commutadore/
Conmutador/SP Wechselschalter

FD16507
Intermediate switch/Interrupteur intermédiaire/Interruttore incrocia-
to/Cruzamiento/Intermediate switch

FD16605
Control one-way/Contrôle/Control one-way/Control/Einweg
Kontroll. 10 A 250 V~

FD16557
One-way SP switch/One-way SP switch/Interruptor simple/One-
way SP switch. 16A 250V~

FD16559
Two-way SP switch/Interrupteur va et vient SP/Two-way SP switch/
Conmutador/Two-way SP switch. 16 A 250 V~

BIPOLAR SWITCH
INTERRUPTEUR BIPOLAIRE
INTERRUPTORE BIPOLARE
INTERRUPTOR BIPOLAR
BIPOLAR-SCHALTER



FD16508
One-way DP switch / Interrupteur standard DP /Interruptor
bipolar simple One-way DP switch 10 A 250 V~

FD16558
One-way DP switch / Interrupteur va et vient DP/Interruptor
bipolar simple DP Ausschalter 16 A 250 V~

Le même mécanisme peut être utilisé pour une touche DP avec
lumière pour une touche de commande DP.

Lo stesso meccanismo può essere usato per un comando
bipolare con diffusore o per un comando bipolare DP.

El mismo mecanismo puede utilizarse para una tecla Bipolar
con difusor o para una tecla Bipolar de control.

Der gleiche Mechanismus kann für DP Schlüssel mit Licht oder
Kontrollschlüssel verwendet werden.

PUSH BUTTON MECHANISMS
MÉCANISMES BOUTON-POUSSOIR
MECCANISMI A PULSANTE
MECANISMOS PULSADORES
DRUCKTASTER MECHANISMEN



FD16516
Push-button
Bouton Poussoir
Pulsante
Pulsador
Drucktaster
10 A 250 V~



FD16599
Push-button with temporized switch and diffu-
ser
Timing 3 min. Max 500 W incandescent 230 V~
Interrupteur bouton poussoir avec minuterie et lumière
Synchronisation 3 min. Max 500 W à incandescence
230 V~
Pulsante con interruttore temporalizzato e diffusore
Tempo minimo 3min. Max 500 W incandescente 230 V~
Pulsador con interruptor temporizador y difusor
Tiempo 3 min. Max 500 W incandescente 230 V~
Taster mit zeitlich einstellbaren Schalter und Diffusor
3 min.
Max 500 W Glühlampe 230V

Universal Switches

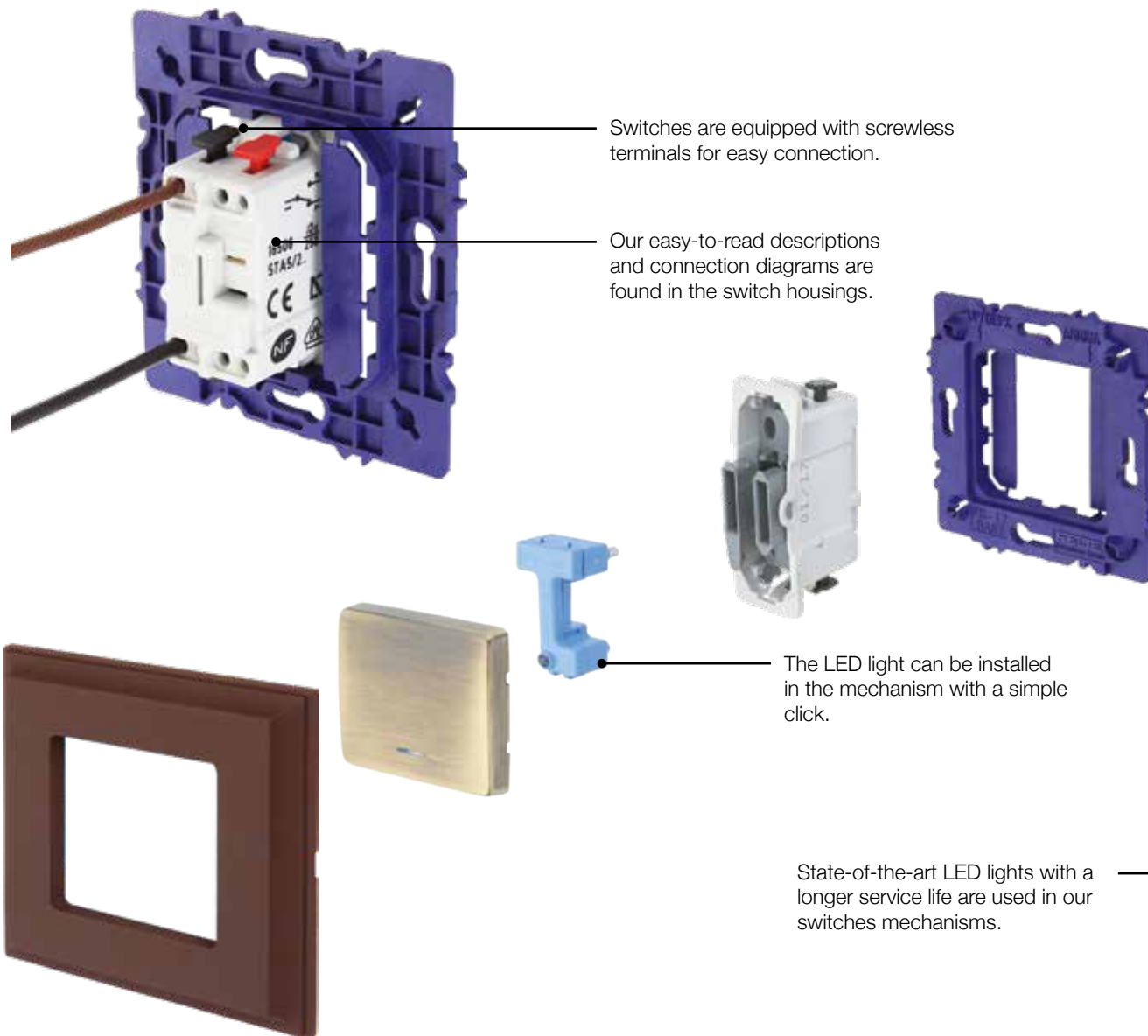

Switches are equipped with screwless terminals for easy connection.

Our easy-to-read descriptions and connection diagrams are found in the switch housings.

The LED light can be installed in the mechanism with a simple click.

State-of-the-art LED lights with a longer service life are used in our switches mechanisms.

The same type of mechanism is used for lighted and non-lighted switches.

LED lights are installed in the switch mechanism by applying slight pressure, connecting automatically.

If necessary, you can change your common switch into a lighted switch. To do this, simply install the LED light and replace the opaque key with the diffuser key.

Switch mechanisms are available in two options: 10 and 16 A.

10A & 16A



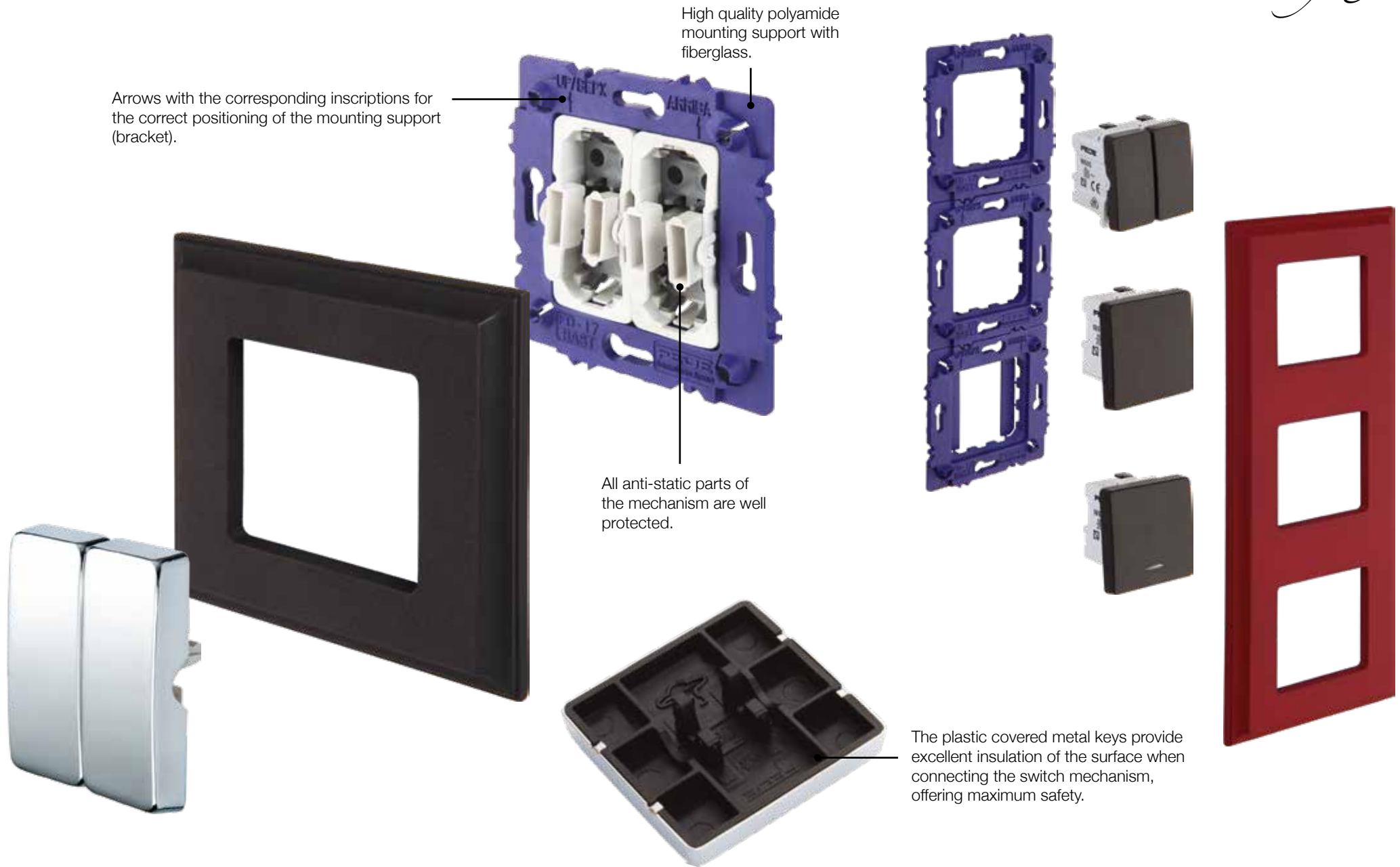

Arrows with the corresponding inscriptions for the correct positioning of the mounting support (bracket).

High quality polyamide mounting support with fiberglass.

All anti-static parts of the mechanism are well protected.

The plastic covered metal keys provide excellent insulation of the surface when connecting the switch mechanism, offering maximum safety.

Devices are protected against humidity



FD16-RING

Protection ring
Anneau de protection
Anello di protezione
Aro de protección
Schutzring

FD17-BAST

Mounting support
with an installed
switch mechanism

FD16-SW44

Isolant accessory
Accessoire isolant
Accessorio isolante
Accesorio aislante
Isolierzubehör

When installing accessories: For the ring cover and the special insulating gasket below the key, you can use a one key switch from the FRAME collection in damp areas with an IP44. We have designed special edges for water drainage on the surface of the insulating gasket.



New Led Toggle Switch

And finally, we present the latest trend that is to turn on a light with a switch that incorporates a transparent toggle illuminated by LED.

How do we do it? Using the same standard switch mechanism. In this way, there is no need to make any additional changes to your project.

It's just great! A detail that does not go unnoticed.



Toggle Switch

All retro style fans, love toggle switches.

Our new toggle switches incorporate an innovative design and the latest technology to become objects of desire.

We have created the “it-switch”. This invention of our FEDE + designers is incredibly MODERN & SOPHISTICATED!

TOGGLE SWITCH



MOUNTING EXAMPLE

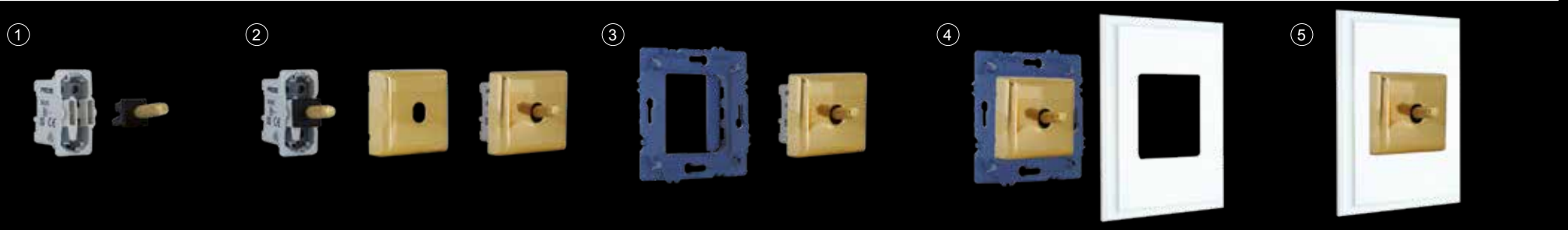

TOGGLE SWITCHES



MOUNTING EXAMPLE

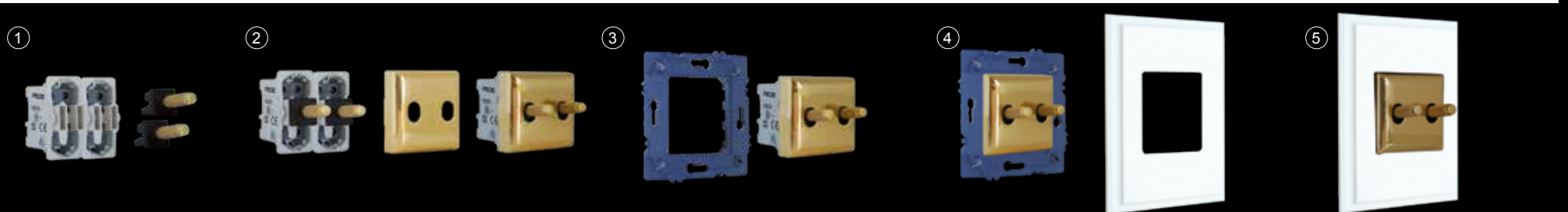

BRASS HANDLES / POIGNÉES EN LAITON / LEVETTE IN OTTONE /
PALANCAS DE LATÓN / MESSINGGRIFFE

NEW LED HANDLES / NOUVELLES POIGNÉES TRANSPARENTES / NUOVE LEZIONI TRASPARENTE LED /
NUEVAS PALANCAS TRANSPARENTES LED / NEUE LED TRANSPARENTHEBEL

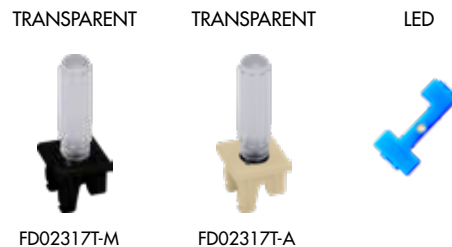

FD21138-1
Blue LED indicator for DP switches and intermediate switches 230 V~ 1mA
Indicateur LED bleu pour interrupteurs DP et interrupteurs intermédiaires 230 V - 1mA
Indicatore LED blu per interruttori DP e meccanismi incrociati 230 V - 1mA
Señalizador de LED azul para interruptores bipolares y cruzamiento 230 V~ 1mA
Blaue LED-Anzeige für DP Ausschalter und Kreuzschalter 230V ~ 1mA

Pack of 20 units / Pack de 20 unidades

LED
FD21138-2
Blue LED indicator for SP switches, push-buttons and two-way switches 230 V~ 1mA
Indicateur LED bleu pour interrupteurs SP, bouton-poussoir et interrupteurs va et vient 230 V - 1mA
Indicatore LED blu per interruttori SP, pulsanti e commutatori 230 V - 1mA
Señalizador de LED azul para interruptores unipolares, pulsadores y conmutadores. 230 V~ 1mA
Blaue LED-Anzeige für SP Ausschalter, Taster und Wechselschalter 230V ~ 1mA

BRASS COVERS / COUVERTURES EN LAITON / COVERS IN OTTONE / TAPAS DE LATÓN / MESSINGABDECKUNGEN

NEW LED HANDLE / NOUVELLE POIGNEE LED / NUOVA LEVETTE LED / NUEVA PALANCA LED / NEUE LED HANDLE

Brass cover for 1 toggle switch
Couverture en laiton pour 1 interrupteur à bascule
Cover in ottone per 1 interruttore a levetta
Tapas de latón para 1 interruptor de palanca
Messingabdeckung für 1 Kippschalter

Brass cover for 2 toggle switches
Couverture en laiton pour 2 interrupteurs à bascule
Cover in ottone per 2 interruttori a levetta
Tapas de latón para 2 interruptores de palanca
Messingabdeckung für 2 Kippschalter

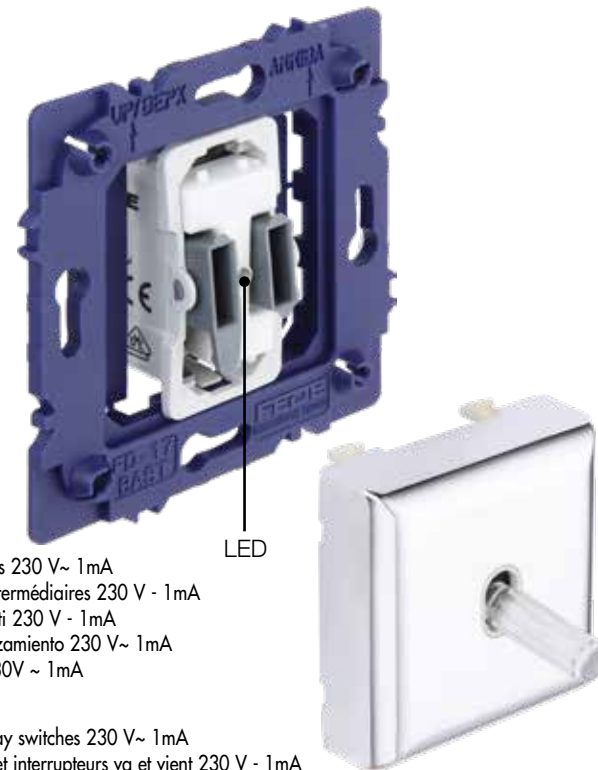

PLASTIC COVERS / COUVERTURES EN PLASTIQUE / NUOVE COVERS DI PLASTICA / TAPAS DE PLÁSTICO / KUNSTOFF OBERTEILEN

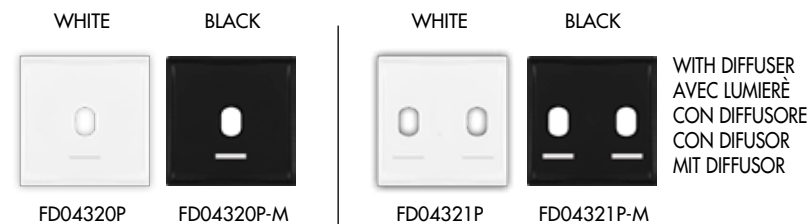

FD21139-1
Blue LED indicator for DP switches and intermediate switches 230 V~ 1mA
Indicateur LED bleu pour interrupteurs DP et interrupteurs intermédiaires 230 V - 1mA
Indicatore LED blu per interruttori DP e meccanismi incrociati 230 V - 1mA
Señalizador de LED azul para interruptores bipolares y cruzamiento 230 V~ 1mA
Blaue LED-Anzeige für DP Ausschalter und Kreuzschalter 230V ~ 1mA

FD21139-2
Blue LED indicator for SP switches, push-buttons and two-way switches 230 V~ 1mA
Indicateur LED bleu pour interrupteurs SP, bouton-poussoir et interrupteurs va et vient 230 V - 1mA
Indicatore LED blu per interruttori SP, pulsanti e commutatori 230 V - 1mA
Señalizador de LED azul para interruptores unipolares, pulsadores y conmutadores. 230 V~ 1mA
Blaue LED-Anzeige für SP Ausschalter, Taster und Wechselschalter 230V ~ 1mA

Please see switch & push-button mechanisms on page 19.

MARCO
COLLECTION



Rotary Switch

Rotary switches are a true embellishment from the collection, combining high switching capacity with a compact size.

The wide range of mechanisms with different connection schemes gives you the possibility to develop any kind of electrical project.

Rotary Switch



Central embellishment in two varieties: metal or plastic.

Our mechanisms occupy as little space as possible in the installation boxes. That way we can free up space for connections and facilitate installation. FEDE+ rotary switches are the most compact and powerful in the market.



10A & 25A

The compact size does not affect power, as FEDE + switches have very high switching capacity, with two switch options for 10A and 25A.

The handles are made of high quality cast brass.



Switches with auxiliary lighting are equipped with state-of-the-art LED lights.



10A 250V~
One-way rotary switch
Interrupteur rotatif standard
Interruttore rotativo standard
Interruptor rotativo simple
Aus-Drehschalter

PLASTIC/PLASTIQUE/PLASTICA/ PLÁSTICO/PLASTIK			BRASS/LAITON/OTTONE/ LATÓN/MESSING	
WHITE	BEIGE	BLACK	GOLD	CHROME
FD03110	FD03110-A	FD03110-M	FD03110-OB	FD03110-CB
FD03111	FD03111-A	FD03111-M	FD03111-OB	FD03111-CB



10A 250V~
Two-way rotary switch
Interrupteur rotatif va et vient
Interruttore rotativo standard
Interruptor rotativo simple
Wechsel-Drehschalter

FD03120	FD03120-A	FD03120-M	FD03120-OB	FD03120-CB
FD03121	FD03121-A	FD03121-M	FD03121-OB	FD03121-CB



10A 250V~
Intermediate rotary switch
Interrupteur rotatif intermédiaire
Invertitore di linea
Interruptor rotativo
de cruzamiento
Kreuzdrehschalter

FD03130	FD03130-A	FD03130-M	FD03130-OB	FD03130-CB
FD03131	FD03131-A	FD03131-M	FD03131-OB	FD03131-CB



10A 250V~
Double one-way SP switch
Interrupteur double va et vient SP
Interruttore rotativo doppio
Interruptor doble rotativo
Serienschalter

FD03140	FD03140-A	FD03140-M	FD03140-OB	FD03140-CB



25A 250V~
One-way rotary switch
Interrupteur rotatif standard
Interruttore rotativo standard
Interruptor rotativo simple
Drehbarer Ausschalter

PLASTIC/PLASTIQUE/ PLASTICA/PLÁSTICO/PLASTIK		
WHITE	BEIGE	BLACK
FD03150	FD03150-A	FD03150-M
BRASS/LAITON/OTTONE/LATÓN/MESSING		
GOLD	CHROME	
FD03150-OB	FD03150-CB	



25A 250V~
Double Pole rotary switch
Interrupteur rotatif à double pôle
Interruttore rotativo doppio
Interruptor doble rotativo
Doppelpoliger Drehschalter

PLASTIC/PLASTIQUE/PLASTICA/PLÁSTICO/PLASTIK		
WHITE	BEIGE	BLACK
FD03160	FD03160-A	FD03160-M
BRASS/LAITON/OTTONE/LATÓN/MESSING		
GOLD	CHROME	
FD03160-OB	FD03160-CB	

**BRASS HANDLES FOR ROTARY SWITCHES
POIGNÉES EN LAITON POUR INTERRUPTEURS ROTATIFS
MANOVELLE IN OTTONE PER INTERRUTTORI ROTANTI
MANECILLAS DE LATÓN PARA INTERRUPTORES ROTATIVOS
MESSINGGRIFFE FÜR DREHSCHALTER**



FD02315OB
 FD02315CB
 FD02314OB
 FD02314CB
 FD02312OB
 FD02312CB
 FD02311OB
 FD02311CB
 FD02310OB
 FD02310CB

**LED PILOT LAMPS/VOYANT LED/SEGNALETICA LED/SEÑALIZADOR LED/
LED-KONTROLLAMPEN**



FD188LED220-1 White/Blanc/Bianco/Blanco/Weiss
 FD188LED220-2 Blue/Bleu/Blu/Azul/Blau
 FD188LED220-3 Amber/Ambre/Ambra/Ámbar/Amber



Multiple Function Controller

This controller integrates multiple functions in one unit. It is designed as a replacement for the bathroom fan and light switch, and uses a microprocessor to control the fan delay-off operation. The Delay Timer function allows the fan to continue operating to complete the ventilation of the bathroom after use.

Infrared Light Switch

Replacing a regular wall switch, this unit automatically turns lights on when someone enters in a room. It increases energy savings by automatically turning lights off after only momentary occupancy. An integrated Light-Dependent-Resistor prevents lights from turning on when the room has adequate natural light. The combination of PIR and light-level detection technology provide excellent lighting control reliability. The slide-selector provided for conveniently switching light on/off manually or to enable PIR/CDS to operate automatically.

TOUCH SWITCHES / INTERRUPTEURS TACTILES / INTERRUTTORI TATTILI / INTERRUPTORES TÁCTILES / BERÜHRUNGSSCHALTER

Individual-light switch
600W. Pack of 1 unit

Interrupteur Individuel
600W. Pack de 1 unité



FD28601 FD28601-A FD28601-M

Fixing support included Support de fixation inclus Bastidor incluido

Double-key-light switch
2x600W. Pack of 1 unit

Interrupteur avec deux touches
2x600W. Pack de 1 unité



FD28602 FD28602-A FD28602-M

Fixing support included Support de fixation inclus Bastidor incluido

Bathroom light switch
Lighting 800W. Ventilation 150W. Pack of 1 unit

Interrupteur multifonction pour la salle de bain
Lumière 800W. Ventilation 150W. Pack de 1 unité



FD28603 FD28603-A FD28603-M

Fixing support included Support de fixation inclus Bastidor incluido

Infrared light switch
800W. Pack of 1 unit

Interrupteur avec détecteur de mouvement de présence
800W. Pack de 1 unité



FD28604 FD28604-A FD28604-M

Fixing support included Support de fixation inclus Bastidor incluido

Switch for Blinds



SWITCHING MECHANISMS FOR BLINDS / MÉCANISMES ÉLECTRIQUES POUR LES STORES / MECCANISMI ELETTRICI PER PERSIANE / MECANISMOS CONMUTABLES PARA PERSIANAS / SCHALTMECHANISMEN FÜR JALOUSIE



Double push-button for blinds. With electrical interlocking device.
Double bouton poussoir pour stores. Avec dispositif de verrouillage électrique.
Doppio bottone a pulsante per persiane. Con dispositivo di blocco elettrico.
Doble pulsador para persianas. Enclavamiento eléctrico.
Doppeldruckknopf für Jalousie. Mit elektrischen Verriegelungsmechanismus.

FD17665
10 A 250 V~

Switch for blinds. With electrical and mechanical interlocking device.
Interrupteur pour stores. Avec dispositif de verrouillage électrique.
Interruttore per persiane. Con dispositivo di blocco elettrico.
Interruptor para persianas. Enclavamiento eléctrico y mecánico.
Schalter für Jalousie. Mit elektrischer und mechanischer Verriegelungsmechanismus.

FD17669
10 A 250 V~

PLASTIC NARROW KEYS/TOUCHES ÉTROITES EN PLASTIQUE/PULSANTE STRETTO IN PLASTICA/ TECLAS ESTRECHAS DE PLÁSTIC/SCHMALE KUNSTSTOFFSCHLÜSSEL



These mechanisms are provided with a security system that prevents the up and down signal being sent simultaneously.
Ces mécanismes ont un système de sécurité qui empêche le signal de vers le haut et vers le bas d'être envoyé simultanément.
Questi meccanismi sono dotati di un sistema di sicurezza che impedisce al segnale di scorrere in alto e in basso simultaneamente.
Estos mecanismos cuentan con un sistema de seguridad para evitar la llegada de los de arriba /abajo la señal de forma simultánea.
Diese Mechanismen sind mit einem Sicherheitssystem, damit verhindert wird das die Auf- und Abwärtssignale nicht gleichzeitig gesendet werden.

BRASS KEYS/TOUCHES EN LAITON/PULSANT IN OTTONE/ TECLAS DE LATÓN/METAL-SCHLÜSSEL





Touch Dimmer

Our touch dimmer is a smart and modern device, which significantly expands the ability to control lighting.

DIMMER / VARIATEUR / REGOLATORE / REGULADOR DE LUZ / DREHDIMMER



Compact touch Dimmer for all FEDE frames collections
Nouveau variateur tactile pour toutes les collections FEDE
Nuovo regolatore a tatto per tutte le collezioni FEDE
Regulador de luz táctil compacto para todos los marcos de FEDE
Tastdimmer für alle FEDE kollektionen

230V 50Hz / 600W

WHITE



FD28625

BEIGE



FD28625-A

BLACK



FD28625-M



Rotary Dimmer

At FEDE+, we have the best master metal craftsmen. The rotary hands of the dimmer are made of genuine brass with a hand-crafted finish.

A refined luxury detail for your decorative project. Your touch will not leave you indifferent!

DIMMER / VARIATEUR / REGOLATORE / REGULADOR DE LUZ / DREHDIMMER



WHITE



FD16438

BEIGE



FD16438-A

BLACK



FD16438-M

Rotary dimmer for all FEDE collections
Nouveau variateur pour toutes les collections FEDE
Nuovo regolatore per tutte le collezioni FEDE
Regulador de luz para todas las colecciones de FEDE
Drehdimmer für alle FEDE kollektionen

16A / 750W

DIMMER WITH DECORATIVE BRASS COVER / VARIATEUR AVEC COUVERTURE EN LAITON / REGOLATORE DI LUCE CON COVERS IN OTTONE /
REGULADOR DE LUZ CON TAPA DE LATÓN / NEUE DREHDIMMER MIT MESSINGABDECKUNGEN



CHROME



FD16438CB-A

GOLD



FD16438OB-A

BRASS ROTARY HANDLES / POIGNÉES ROTATIVES EN LAITON / MANOPOLA ROTATIVA IN OTTONE /
BOTÓN GIRATORIO DE LATÓN / MESSINGDREHGRIFFE



CHROME



FD04336CB

GOLD



FD04336OB

*To change plastic rotary handle for brass rotary handle, you just need to replace the plastic one and put another type from brass. Plastic handle is included with dimmer mechanism.

*Pour changer les poignées rotatives en plastique en poignée rotative en laiton, vous avez juste à remplacer celle en plastique pour celle en laiton. La poignée en plastique est incluse avec le mécanisme du variateur.

*Per sostituire le manopole in plastica con quelle in ottone, è sufficiente sostituire la plastica per l'ottone. La manopola in plastica è inclusa con il meccanismo dimmer.

*Para cambiar el botón giratorio de plástico por el botón giratorio de latón, basta con sustituir el de plástico colocando el de latón. El botón de plástico está incluido con el mecanismo del regulador de luz.

*Für den Wechsel von Kunststoff Drehgriff für Messingdrehgriff, müssen Sie nur Kunststoffdrehgriff mit einem anderen Messingtyp ersetzen. Kunststoffgriff ist beim Dimmer Mechanismus inbegriffen.

Dimmers for Push Buttons



Designation	FD-LD100	FD-LD220	FD-LD440
Item number	V-4010020IB	V-4022010IB	V-4044020IB
Power	1-100W	1-200W	1-440W
Voltage	230V +/-10% 50/60 Hz	230V +/-10% 50/60 Hz	230V +/-10% 50/60 Hz
Max current	0,43A	0,87A	1,91A
For dimming of			
- Dimmable 230V LED	1-100W	1-200W	1-440W
- Dimmable LED driver for phase control	1-100W	1-200W	1-440W
- Dimmable CFLs	1-100W	1-200W	1-440W
- 230V halogen lamps	1-100W	1-200W	1-440W
Electronic transformers	1-100W	1-200W	1-440W
Incandescent light	1-100W	1-200W	1-440W
Has adjustable minimum dimming level	Yes	Yes	Yes
Memorises the last set brightness, even after power failure	Yes	Yes	Yes
With motion detection / twilight relay / timer	Yes	Yes	Yes
Is controlled up to 5 reactive toggle switches	Yes	Yes	Yes
With soft start	Yes	Yes	Yes
Dimension	Ø56 H22 mm	Ø56 H22 mm	Ø56 H22 mm

Wider dimming range	Wider dimming range, starts already at 1 W
Excellent test ratings	0-100% dimming
Adjustable min. dimming level	Highest ratings in tests of 25 leading brands of 230 V LED-lamps. Average rating 4,7 points out of 5. 15 lamps scoring 5 out of 5. Different minimum settings possible for LED-lamps and CFL.

Dimmers for Push Buttons



FD16516
10A 250V~
Push-button
Pousse-bouton
Pulsante
Pulsador
Drucktaster



FD16599
Push-button with temporized switch and diffuser. Timing 3 min. Max 500W incandescent 230V~
Bouton-poussoir avec interrupteur et diffuseur temporisé. Synchronisation 3 min.
Max 500Wà incandescence 230V~
Pulsante con interruttore temporalizzato e diffusore. Tempo minimo 3min.
Max 500W incandescente 230 V~
Pulsador con interruptor temporizador y difusor. Tiempo 3 min. Max 500W incandescente 230V~
Taster mit zeitlich einstellbaren Schalter und Diffusor 3 min. Max 500W Glühlampe 230V

PUSH BUTTON MECHANISMS
MÉCANISMES BOUTON-POUSSOIR
MECCANISMI A PULSANTE
MECANISMOS PULSADORES
DRUCKTASTER MECHANISMEN

FD-LD100, FD-LD220 and FD-LD440

Universal push dimmers FD-LD100, FD-LD220 and FD-LD440

Universal LED-dimmers for wallbox installation that starts at 1W

A common problem - when dimming LED lamps and CFL lamps - is that conventional dimmers usually require a high minimum load of 50W, 35W or 20W, while low energy light lamps and LED lamps have a power range from 1W up to 20W. For dimming of these low energy lamps dimmers that can operate from 1W and up are required. The series of universal push dimmers starts already at 1W for dimming of both lowpower lamps as well as electronic transformers, dimmable LED-drivers and incandescent lamps.

Adjustable minimum dimming level

Depending on the type of load that is connected to the dimmer, the dimmer's lowest dimming level can be adjusted to fit the load in question. The dimming characteristic is distinguished between different types of loads. This feature is perfect for use when there is mixed loads of different lamptypes including dimmable halogen and incandescent lights. It is also very handy if the user at some future date decides to switch from incandescent to 230 VAC dimmable LEDs. Then you need only adjust the lowest dimming level to the new load, instead of buying a new dimmer.

Memory function

Equipped with memory function that also remains after power failure.



FD-LD220
Dimmer for LED lamp
Power: 200W
230V 50/60 Hz
Installed in the mounting box
behind the push button.
Dimensions: 56 x 22 mm
Units: 1



FD-LD440
Dimmer for LED lamp
Power: 440W
230V 50/60 Hz
Installed in the mounting box
behind the push button.
Dimensions: 56 x 22 mm
Units: 1



FD-LD220WCM
LED dimmer with Bluetooth®
Power: 200W
230V 50/60 Hz
Installed in the mounting box
behind the push button.
Dimensions: 50 x 15.5 mm
Units: 1



LD200KRON
2 channel dimmer for LED lamp
Power: 2x100W
230V 50/60 Hz
Installed in the mounting box
behind the push button.
Dimensions: 57 x 21 mm
Units: 1



App: Dimmers for Push Buttons

First time use

Casambi app is easy to use. Follow these simple steps.

1. Download the app from Apple App Store or Google Play Store.
2. Turn on your Casambi enabled luminaires.
3. Open the app.
4. Casambi app will automatically find all Casambi enabled luminaires that are switched on.
5. Tap on the "Take all lamps into use".
6. Casambi app will automatically add all luminaires to one network and open the "Lamp" tab.

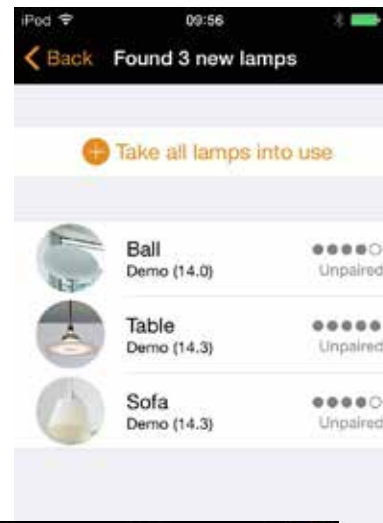

Scenes and animations

In the "Scenes" tab you can create different lightings for different occasions. It is possible to control multiple luminaires with one tap to create perfect ambience. One luminaire can be used in several scenes.

1. Tap on "Add a scene" and enter a name for the scene. Select the "Add a scene" option.
2. Select one or multiple lamp controls and adjust the luminaires for the scene. You can adjust the luminaires separately or if you want to have same dim level or colour for all you can use the "Lamps in scene" control to adjust all luminaires in the scene.
3. When you are done editing the scene tap on "Done".
4. If you would like to create more scenes tap on the "Edit" on top right corner and then tap on the "+" sign.

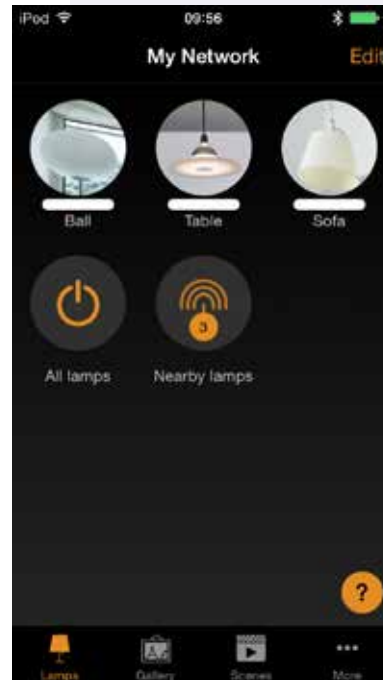

Basic gestures

Here are the basic gestures how to control your lights.

- To turn off or on your luminaire just tap on the lamp control.
- Pan lamp control left or right to adjust light level of the luminaire.
- Pan lamp control up or down to adjust the colour temperature of the luminaire.
- Hold on top of the lamp control to change the colour and save colours to palette.

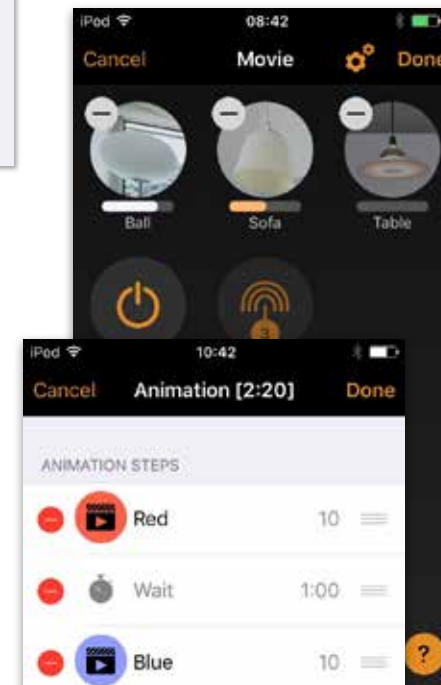

Please consult our Technical Data for more information or contact: www.casambi.com | support@casambi.com

www.casambi.com
support@casambi.com

Night Light Indicator

*ITEMS' REAL SIZE ARE SHOWN IN THE IMAGES



Our NIGHT LIGHT INDICATOR is particularly designed for directional guiding in dim environments, they can be situated in rooms, stairways or at any required location in buildings. Two separate styles are provided for the Night Light Indicator.



1. FD28606 White-Red colored LED selectable
2. FD28607 RGB color changeable LED

Electronic devices with minimal power consumption. 17 styles of self-adhesive front-panel stickers are available optionally.

NIGHT LIGHT INDICATOR / NOUVEAUX VOYANTS / NUEVOS SEÑALIZADORES LUMINOSOS

Night Light Indicator White-Red colored LED selectable for all FEDE Collections
Fixing support included
Pack of 1 unit

Voyants LED disponible en blanc et rouge pour toutes les collections pour toutes les collections FEDE.
Support de fixation inclus
Pack de 1 unité

Señalizador luminoso LED disponible en blanco y rojo para todas las colecciones FEDE.
Bastidor incluido
Pack de 1 unidad

FD28606

RED & WHITE
ROJO y BLANCO
ROUGE ET BLANC



Night Light Indicator RGB color changeable LED for all FEDE Collections
Fixing support included
Pack of 1 unit

Voyants LED de couleur RGB pour toutes les collections FEDE.
Support de fixation inclus
Pack de 1 unité

Señalizador luminoso LED de color RGB para todas las colecciones FEDE.
Bastidor incluido
Pack de 1 unidad

FD28607

RGB
RGB



STICKERS / ETIQUETTES / ETIQUETAS

FINISHES AVAILABLE Stickers for Night Light Indicator Pack of 1 unit

ACABADOS DISPONIBLES
FINITIONS DISPONIBLES

ALUMINIUM / ALUMINIUM / ALUMINIO
FD28608-A, FD28609-A, FD28620-A, FD28621-A,
FD28622-A, FD28623-A

GOLD / OR / ORO
FD28608-G, FD28609-G, FD28620-G, FD28621-G,
FD28622-G, FD28623-G

Etiquettes pour les voyants. Pack de 1 unité
Etiquetas para el Señalizador luminoso. Pack de 1 unidad

*For Aluminium (A), gold (G) and Black (B) finish for reference FD28624, please add A, G or B at the end.

*Pour l'Aluminium (A), l'or (G) et le noir (B) dans les finitions pour la référence FD28624, veuillez, s'il-vous plaît, ajouter un A, G ou B à la fin de référence.

*Para Aluminio (A), Oro (G) y Negro (B) en los acabados FD28624, por favor añadir una A, G o B al final de la referencia.

FD28624-A FD28624-G FD28624-B



FD28608 FD28609 FD28610 FD28611 FD28612 FD28613 FD28614 FD28615 FD28616 FD28617 FD28618 FD28619 FD28620 FD28621 FD28622 FD28623 FD28624

For customized stickers, please contact us.

Pour personnaliser les etiquettes, veuillez nous contacter.

Para personalizar las etiquetas, por favor contáctanos.

New USB Charger

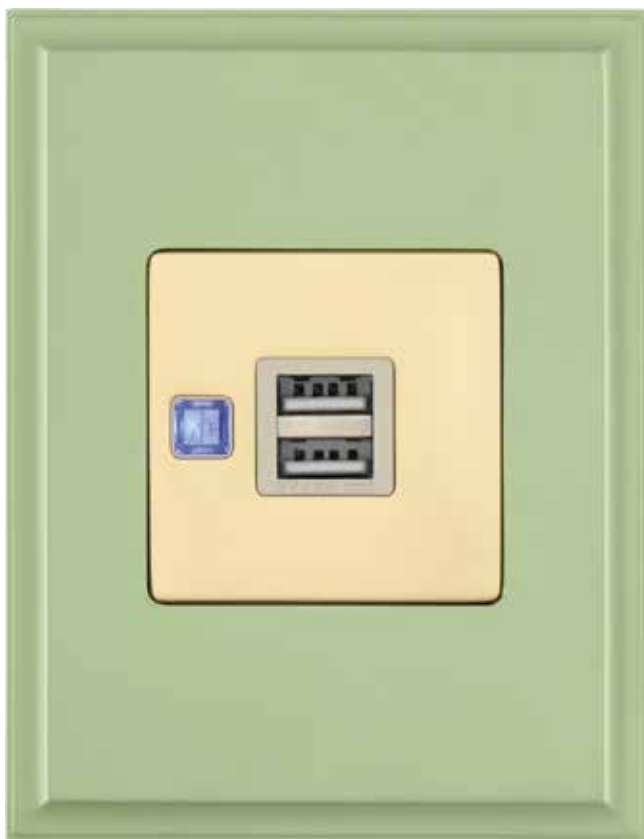

This product (hereinafter referred to as FD-212USB) is designed to follow users needs to do a combination of elasticity after once installed, can completely replace the existing function of external chargers, and save the cost compared to the external charger. FD-212USB can convert general AC power supply into USB power very easy, Charge electricity quickly and save time.



5VDC - 2A

MECHANISMS WITH FRONT PLASTIC COVERS
MÉCANISMES AVEC COUVERCLES EN PLASTIQUE
MECCANISMI CON COVERS DI PLASTICA
MECANISMOS CON TAPAS DE PLÁSTICO
MESSINGKAPPE MECHANISMUS

WHITE



FD-212USB

BEIGE



FD-212USB-A

BLACK



FD-212USB-M

MECHANISMS WITH BRASS COVERS / MÉCANISME AVEC COUVERCLES EN LAITON / MECCANISMI CON COVERS IN OTTONE / MECANISMOS CON TAPAS DE LATÓN / MESSINGABDECKUNGEN

CHROME



FD-212USBCB-A

GOLD



FD-212USBOB-A

NEW USB CHARGER DOUBLE OUTPUT PORT

USB charger can charge mobile phones and Smartphones, MP3 players, MP4s and iPods, tablets and iPads, digital cameras, Sat Navs and game consoles.
High performance, functionality, reliability and quality.

El cargador USB puede cargar teléfonos móviles y Smartphones, reproductores MP3, MP4s y iPods, Tablets y iPads, cámaras digitales, navegadores por satélite y video consolas.
Alto rendimiento, funcionalidad, fiabilidad y calidad.

Le chargeur USB peut recharger les téléphones mobiles, les Smartphones, lecteurs MP3, MP4, iPods, tablettes et iPads, appareils photo digitales, tablettes tactiles et les consoles de jeux.
Haute performance, fonctionnalité, fiabilité et qualité.

USB Ladegerät für Mobiltelefone, Smartphones, MP3-Player, MP4s, iPods, Tablets und iPads, Digitalkameras, Navigationsgeräte und Spielekonsolen.
Hohe Leistung, Funktionalität, Zuverlässigkeit und Qualität.

Il caricatore USB può caricare cellulari e Smartphones, players MP3, MP4 e iPods, Tablets e iPads, fotocamere digitali, navigatori satellitari e video consolas.
Alta performance, funzionalità, affidabilità e qualità.

SPECIFICATIONS / CARACTÉRISTIQUES / SPECIFICHE / ESPECIFICACIONES / TECHNISCHE DATEN

INPUT: 110~230VAC, 50~60HZ, 0.3A

OUTPUT: 5VDC, 2A TOTALLY

PORT1 ONLY OR PORT1 + PORT2

STANDBY: BLUE 

CHARGING: RED 

CHARGED: GREEN 

REGULATION: USB DCP, BC 1.2 STANDARD

AUTO DETECTION OF USB D+/D- LINE VOLTAGE

INTELLIGENT CHARGE-CURRENT CONTROL ON PORT 1, MAX. 2A

STORAGE TEMPERATURE: -10 +40°C

USAGE TEMPERATURE: -10 +40°C

HUMIDITY: 0-60% NON-CONDENSING

ENTRÉE: 110 ~ 230VAC, 50 ~ 60HZ, 0.3A

SORTIE: 5VDC, 2A TOTAL

PORT 1 UNIQUEMENT OU LE PORT 1 + PORT 2 LED ÉTAT

VEILLE: BLEU 

CHARGE: ROUGE 

CHARGÉ: VERT 

RÈGLEMENT: USB DCP, BC 1.2 STANDARD

AUTO DÉTECTION D'USB D+ / D- VOLTAGE

CONTRÔLE INTELLIGENT CHARGE COURANT SUR LE PORT 1, MAX. 2A

TEMPÉRATURE DE STOCKAGE : -10 +40°C

UTILISATION TEMPÉRATURE: -10 +40°C

HUMIDITÉ: 0-60% SANS CONDENSATION

INPUT: 110 ~ 230VAC, 50 ~ 60HZ, 0.3A

OUTPUT: 5VDC, 2A TOTALE

PORT 1 SOLO O PORT 1 + PORT 2

STANDBY: BLEU 

IN CARICA: ROUGE 

CARICO: VERT 

REGOLAZIONE: USB DCP, BC 1.2 STANDARD

AUTORICONOSCIMENTO DI USB D+ / D- VOLTAGE

CONTROLLO INTELLIGENTE DI RICARICA CORRENTE SU PORT 1, MAX. 2A

TEMPERATURA DI STORAGE : -10 +40°C

TEMPERATURE DI UTILIZZO: -10 +40°C

UMIDITÀ: 0-60% SENZA CONDENZA

ENTRADA: 110~230V, 50~60HZ, 0.3A

SALIDA: 5VDC, 2A TOTAL

PUERTO1 SÓLO O PUERTO1 + PUERTO2 STATUS LED

ENCENDIDO: AZUL 

CARGANDO: ROJO 

CARGADO: VERDE 

REGULACIÓN: USB DCP, BC 1.2 ESTÁNDAR

AUTO DETECCIÓN DEL USB D+ / D- VOLTAJE DE LA LÍNEA

CONTROL DEL CARGADOR INTELIGENTE EN PUERTO1, MAX. 2A

TEMPERATURA DE ALMACENAMIENTO: -10 +40°C

TEMPERATURA DE USO: -10 +40°C

HUMEDAD: 0-60% SIN CONDENSACIÓN

EINGANG: 110 ~ 230VAC, 50 ~ 60HZ, 0.3A

AUSGANG: 5 V DC, 2A TOTAL

PORT 1 NUR ODER PORT 1 + 2-PORT-STATUS-LED

STANDBY: BLAU 

LADE: ROT 

GELADEN : GRÜN 

REGELUNG: USB DCP, BC 1.2 STANDARD

AUTOMATISCHE ERKENNUNG VON USB D + / D- LINE VOLTAGE

INTELLIGENTE LADESTROMSTEUERUNG AN PORT 1, MAX. 2A

LAGERTEMPORATUR: -10 BIS +40°C

EINSATZTEMPORATUR: -10 BIS +40°C

LUFTFEUCHTIGKEIT: 0-60% NICHT KONDENSIEREND

REGULATIONS

Glow wire test 650°C

UNE-EN60998-2-1 ,4 Connecting devise for low voltage circuits for household and similar.

CE 2006/95/CE

New Card Switch

Our new hotel card mechanism offers a refined look thanks to its exclusive brass coating. Exquisite finishes for those lovers of unique details that benefit from the latest technology in LED signalling and a maximum to accept cards of different sizes, ranging from 0.7mm to 1.8mm. It supports all frames of the FEDE collections and is installed in a standard European box (60mm), just as the rest of mechanisms shown in this catalogue.z



MARCO
COLLECTION



New Hotel Card Switch



FD17-BAST

FD16516

FD21139-2

FD04341OB

FD-4342IT
INTERNAL BUTTON
BOUTON INTERIOR
BOTÓN INTERNO

FD04340-A

Products description:

- Nominal voltage 230VAC, 10A.
- LED color- Blue
- Cables: rigid/flexible/stranded cables with section of 1.5mm²
- Operating ambient temperature from 5 to 35 °C
- Cards thickness min: 0.7 mm - max 1.8 mm
- Degree of protection IP20/IK04

FRONT PARTS WITH COVERS TAPAS EN LATÓN				PLASTIC FRONT COVERS TAPAS DE PLÁSTICO		CORD OPERATED PUSH-BUTTON PULSADOR TIRADOR			10 A 250 V ~
BRIGHT GOLD		BRIGHT CHROME		WHITE	BEIGE	WHITE	BEIGE	CAOBA	
FD04341OB	FD04341OB-A	FD04341CB	FD04341CB-A	FD04340	FD04340-A	FD16021	FD16021-A	FD016021-M	

MARCO
COLLECTION

In-wall **Bluetooth®** *Audio Receiver*

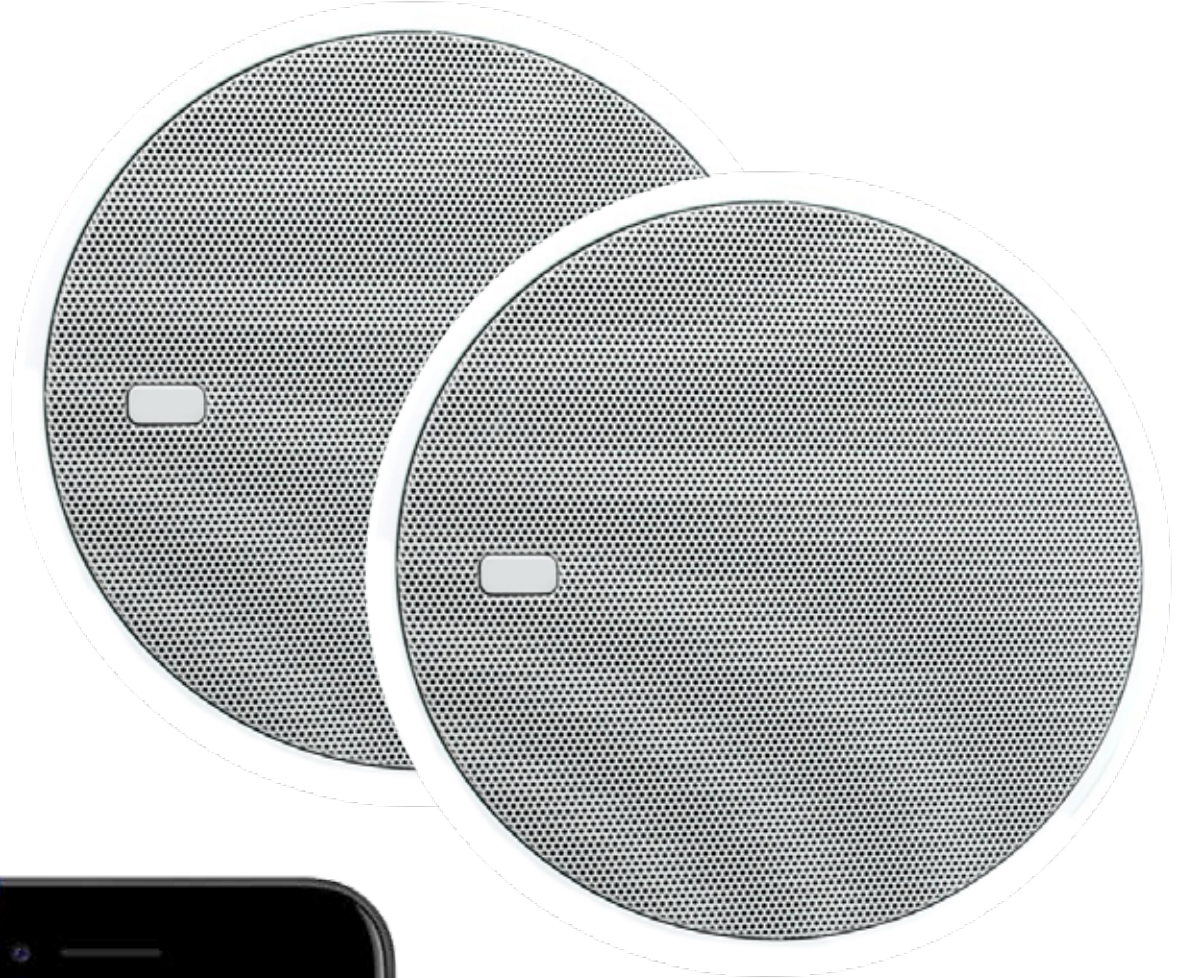

Perfect for home, a great solution for rooms of hotels, hospitals, schools or any public place ...

MARCO
COLLECTION

In-wall **Bluetooth®** *Audio Receiver*



In-Wall Bluetooth Audio receiver that can be paired with any device with Bluetooth® capabilities (A2DP / AVRCP). Fits into the most popular light switches in the market (45 x 45mm).

Signal reach is 10/12 meters.

Designed to ensure security and avoid interferences from other users nearby, each Module has its own identification number.

Perfect for your home, ideal solution for hotel rooms, hospitals, schools and any public place... in the wall avoids theft.

The In-Wall Bluetooth kit, includes:

- In-Wall Bluetooth Audio Receiver
- Two 2 ½" 8Ω loudspeakers
- Power supply (15Vdc/0,8A)
- Control unit frame

WHITE



FD1234

GREY



FD1234-G

BLACK



FD1234-M

BLACK



FD1234AD-M

WHITE



FD1234AD



Installation

Two 4Ω speakers can be connected, up to four 8Ω speakers and up to eight 16Ω speakers.

Maximum power 5 + 5W.

Features

Each module is identified as KINGBT-XXXX where XXXX is a serial number which permits the user to identify different Modules that can co-exist in the same installation.

The module is provided with a key for operating the Bluetooth® mode (ON/OFF).

External audio input: the module is also provided with a socket to connect a 3,5mm jack for an external audio input. When the user inserts the jack the audio output switches to the signal from the jack and has priority over the Bluetooth® signal.

German Socket

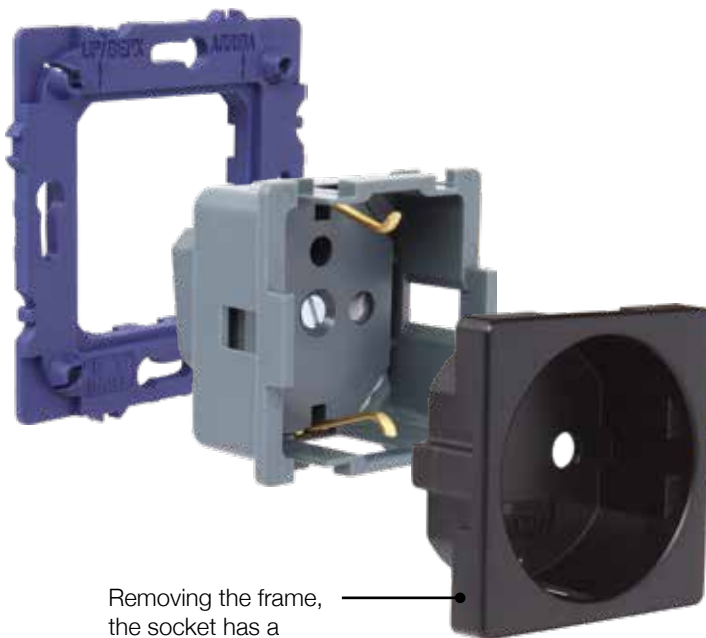

Removing the frame, the socket has a protection degree of IP21.



FD16823
2P + E Socket outlets
Sortie de prises 2P + E
Base de enchufe 2P + E
2P + E Steckdosen
16 A 250 V



BRASS COVERS/COUVERTURE EN LAITON/COVERS IN OTTONE/TAPAS DE LATÓN/MESSINGABDECKUNGEN

	GOLD		
	FD04335OB	FD04335OB-A	FD04335OB-M
CHROME			
	FD04335CB	FD04335CB-A	FD04335CB-M

SOCKET FRONT PLASTIC COVERS
PRISE LARGE EN PLASTIQUE
COVER FRONTALE IN PLASTICA
BASES DE ENCHUFE DE PLÁSTICO
BREITE STECKDOSENABDECKUNGEN MIT DECKEL

WHITE	BEIGE	BLACK
FD16723	FD16723-A	FD16723-M

SOCKET FRONT COVERS WITH TAP
CLAPET LARGE POUR PRISE
COVERS FRONTALE PER PRESA
TAPAS FRONTALES PARA BASES DE ENCHUFE
STECKDOSENABDECKUNG MIT DECKEL

WHITE	BEIGE	BLACK
FD16911	FD16911-A	FD16911-M

FD16-RING
Protection ring
Anneau de protection
Anello di protezione
Aro de protección
Isolierzubehör



MARCO
COLLECTION

French Socket

FD16623
 2P + E Socket outlets
 Sortie de prises 2P + E
 Base de enchufe 2P + E
 2P + E Steckdosen
 10-16 A 250 V



BRASS COVERS/COUVERTURE EN LAITON/COVERS IN OTTONE
 TAPAS DE LATÓN/MESSINGABDECKUNGEN



SOCKET FRONT PLASTIC COVERS
 PRISE LARGE EN PLASTIQUE
 COVER FRONTALE IN PLASTICA
 BASES DE ENCHUFE DE PLÁSTICO
 BREITE STECKDOSENABDECKUNGEN MIT DECKEL



SOCKET FRONT COVERS WITH TAP
 CLAPET LARGE POUR PRISE
 COVERS FRONTALE PER PRESA
 TAPAS FRONTALES PARA BASES DE ENCHUFE
 STECKDOSENABDECKUNG MIT DECKEL



FD16-RING
 Protection ring
 Anneau de protection
 Anello di protezione
 Aro de protección
 Isolierzubehör



Removing the frame,
 the socket has a
 protection degree
 of IP21.



British Socket



BRASS COVERS/COUVERTURE EN LAITON/
COVERS IN OTTONE/TAPAS DE LATÓN
MESSINGABDECKUNGEN



16A 230V



American Socket



BRASS COVERS/COUVERTURE EN LAITON/
COVERS IN OTTONE/TAPAS DE LATÓN
MESSINGABDECKUNGEN



15A 127V

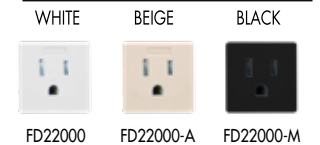

BRASS COVERS/COUVERTURE EN LAITON/
COVERS IN OTTONE/TAPAS DE LATÓN/
MESSINGABDECKUNGEN

CHROME

GOLD



FD21000CB

FD21000OB



FD21000CB-A

FD21000OB-A



FD21000CB-M

FD21000OB-M

16 A 230 V

WHITE

BEIGE

BLACK



FD21000

FD21000-A

FD21000-M

WHITE

BEIGE

BLACK



FD16090

FD16090-A

FD16090-M

Base de enchufe 2P mixta

Para clavija europea

10/16 A 250 V ~

Anneau de protection

15 A 125 V ~

Solo para exportación

Envase 20

WHITE

BEIGE

BLACK



FD16190

FD16190-A

FD16190-M

Base de enchufe 2P+T mixta

Para clavija europea

10/16 A 250 V ~

Anneau de protection

15 A 125 V ~

Solo para exportación

Envase 20

Euro-American Socket



MARCO
COLLECTION



TV/SAT Socket Outlets

We are offering wide range of professional TV/SAT socket outlets:

The compact dimension of the mechanisms ensure fixation of cables and installation to the mounting box in the wall.

BRASS TV/SAT COVERS / COUVERTURES TV/SAT EN LAITON / TAPAS TV/SAT DE LATÓN

CHROME
CROMO



FD04315CB-A (Beige)
FD04315CB-M (Negro)

GOLD
ORO



FD04315OB-A (Beige)
FD04315OB-M (Negro)

CHROME
CROMO



FD04316CB-A (Beige)
FD04316CB-M (Negro)

GOLD
ORO



FD04316OB-A (Beige)
FD04316OB-M (Negro)

TV/SAT COVERS / COUVERTURES TV/SAT / TAPAS TV/SAT

Cover for mechanism with single connector
Couverture pour la prise avec un connecteur simple
Tapa para toma con 1 conector

Cover for mechanism with double connector
Couverture pour la prise avec un connecteur double
Tapa para toma con doble conector

WHITE
BLANCO



FD0321

BEIGE
BEIGE



FD0321-A

BLACK
NEGRO



FD0321-M

WHITE
BLANCO



FD0322

BEIGE
BEIGE



FD0322-A

BLACK
NEGRO



FD0322-M

WIDE/LARGE/ANCHAS

WHITE
BLANCO



FD0323

BLACK
NEGRO



FD0323-M

NARROW/CLAIR/ESTRECHAS

½ TV Please see on
page 53 to combine
this item with multimedia.

NEW!

MARCO
COLLECTION

TV/SAT Socket Outlets

- DIECAST BOXES
- SMALL DIMENSIONS
- HIGH EFFICIENCY SHIELD > 90 dB
- ULTRA WIDE BAND WITHIN 4/ 2350 MHZ
- HIGH LINEARITY AND RETURN LOSS IN WHOLE BAND
- SILVERED CONTACTS
- SUITABLE FOR DIGITAL AND ANALOG TV/SAT SIGNALS

Door opening angle greater than 180° in order to facilitate the installation even under difficult conditions.

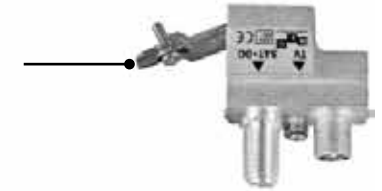

Features:

- Facilitated entrance of the door screw.
- Curvature designed to tightening different diameters cables in uniform way.



Ø 3,50 mm

Ø 8,00 mm

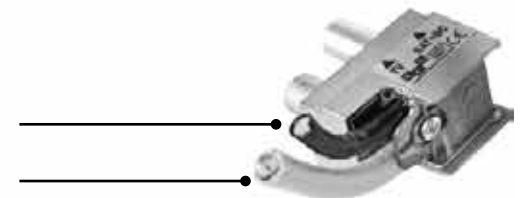

miniCOMPACT outlet with
CONNECTOR F female



miniCOMPACT outlet with
IEC male diecast



miniCOMPACT outlet
TV/SAT diplexed
with F and IEC male
connectors

miniCOMPACT OUTLET SERIES / PRISES TV/SAT SERIE miniCOMPACT / TOMAS TV/SAT SERIE miniCOMPACT

Single sockets TV or SAT

CODE	SCHEME	DESCRIPTION	MODEL	TYPICAL USE
FD001F/DC		Terminal IEC pin RF with DC		TV system DC with a single connectivity RETRO TV
FD002F		Terminal F-OUT RF socket with DC		SAT network with multiswitch 4/8
FD001F		End IEC pin OUT RF isolated		Terminal TV socket for network with a "cascade" connection
FD506F		Passageway IEC pin OUT RF isolated	3 dB 6 dB 10 dB 14 dB 18 dB 22 dB	TV network DC with a "cascade" connection

Sockets TV/SAT

CODE	SCHEME	DESCRIPTION	MODEL	TYPICAL USE
FD010F		End OUT SAT with DC OUT TV isolated		TV / SAT networks with a "star" connection
FD011F		End Independent inputs OUT SAT with DC OUT TV isolated		With independent connections of two cables
FD013F		End OUT SAT isolated OUT TV isolated		End TV / SAT socket for network with a "cascade" connection.
FD220F		Passageway OUT SAT isolated OUT TV isolated	3 dB 6 dB 10 dB 14 dB	TV / SAT networks with a "cascade" connection

Notes: DC-diode set between OUT and IN. For more information on connection diagrams, see page 71.

COMPACT OUTLET SERIES / PRISES SERIE COMPACT / TOMAS SERIE COMPACT



FD090F

Aluminum alloy support
for fixing connectors



FD091F

F-F connector



FD092F

F-IEC-pin connector

The FD090F support is made of an aluminum alloy with a high shielding ability and, depending on your needs, allows mounting one or two FD091F or FD092F connectors. This kit is installed in the circuit boards. Despite the fact that ecoCOMPACT is the most economical solution, it has a very wide operating range from 4 to 235 MHz and provides compatibility with analog and digital TV / SAT signals.

Multimedia Sockets



FEDE+ presents a new product line of brass covers for Multimedia sockets. Our new decorative covers provide a luxury finish to Multimedia outlets thanks to their excellent quality.

COVERS FOR MULTIMEDIA SOCKETS / COUVERTURE EN LAITON POUR LES PRISES MULTIMÈDIA /
TAPAS CONNETTORI MULTIMEDIALI PER BRASS / TAPAS PARA CONECTORES MULTIMEDIA DE LATÓN /
TAPAS CONNECTORS MULTIMEDIA FÜR BRASS

BRIGHT GOLD



FD04318OB-A (Beige)
FD04318OB-M (Black)



FD04317OB-A (Beige)
FD04317OB-M (Black)

BRIGHT CHROME



FD04318CB-A (Beige)
FD04318CB-M (Black)



FD04317CB-A (Beige)
FD04317CB-M (Black)

COVERS FOR MULTIMEDIA SOCKETS / COUVERTURE EN PLASTIQUE POUR LES PRISES MULTIMÈDIA /
TAPAS CONNETTORI MULTIMEDIALI PER PLASTICA / TAPAS PARA CONECTORES MULTIMEDIA DE PLÁSTICO /
TAPAS CONNECTORS MULTIMEDIA FÜR KUNSTSTOFF

Single mounting plate
Pack of 10 units

WHITE

BEIGE

BLACK

Plaque pour le montage d'une prise multimédia
Pack de 10 unités



Módulo para el montaje de 1 conector multimedia
Pack de 10 unidades

FD17896

FD17896-A

FD17896-M

Double mounting plate
Pack of 10 units



Plaque pour le montage deux prise multimédia
Pack de 10 unités

FD17897

FD17897-A

FD17897-M

Módulo para el montaje de 2 conectores multimedia
Pack de 10 unidades

NARROW/CLAIR/ESTRECHAS

½ TV Please see on
page 50 to combine
this item with TV/SAT.

WHITE

BLACK









NEW!





FD17898

FD17898-M

PHONE, COMPUTER AND AUDIO CONNECTORS / GAMME MULTIMÉDIA / GAMA MULTIMEDIA

	6 contacts phone socket For RJ-11 connector Cat. 3e Pack of 1 unit.	Prise téléphonique de 6 voies Pour le connecteur RJ-11. Cat. 3e Pack de 10 unités.	Toma teléfono 6 vías Para conector RJ-11. Cat. 3e Pack de 1 unidad.	FD-T3-B	FD-T3-M
	Information outlets (internet), Cat. 6e Pack of 1 unit.	Prise informatique (Internet), Cat.6e Pack de 1 unité.	Toma informática (Internet), Cat. 6e Pack de 1 unidad.	FD-T6-B	FD-T6-M
	HDMI connector Pack of 1 unit	Connecteur HDMI Pack de 1 unité.	Conector HDMI Pack de 1 unidad	FD-210HD	FD-210HD-M
	USB connector Jack-to-jack connection, 2.0A-A, nickel coating Pack of 1 unit	Connecteur USB Connexion Jack -to-jack, 2.0A-A, finition en nickel Pack de 1 unité.	Conexión USB Conector Jack-to-jack, 2.0A-A, acabado en níquel Pack de 1 unidad	FD-210USB	FD-210USB-M
	RCA connector, Audio, nickel coating Pack of 1 unit	Connecteurs RCA Audio, finition nickel Pack de 1 unité.	Conector RCA Audio, acabado en níquel Pack de 1 unidad	FD-310RSA-YL	FD-310RSA-YL-M
	BANANA audio outlet Pack of 1 unit	BANANA connecteur audio Pack de 1 unité.	BANANA conector audio Pack de 1 unidad	Red / Rouge / Rojo Black / Noir / Negro FD-BJ-B-R FD-BJ-B-M	FD-BJ-M-R FD-BJ-M-M
	Audio outlet for plugs Ø3.5mm Pack of 1 unit	Prises Jack audio Ø3.5mm Pack de 1 unité.	Toma de audio para enchufes Ø3.5 mm Pack de 1 unidad	FD-35S-B	FD-35S-M
	Self-clamping audio outlet Pack of 1 unit	Prise audio à pinces Pack de 1 unité.	Toma de audio de pinzas Pack de 1 unidad	FD-310ST	FD-310ST-M

FIBER-OPTIC CONNECTORS / CONNECTEURS OPTIQUES FIBRES / CONECTORES DE FIBRA ÓPTICA

	ST connector PB sleeve, 19.20mm Individual Pack of 1 unit	Douille de connecteur PB ST, 19,20 mm Pack individuel de 1 unité	Manga de conector PB ST, 19.20mm Pack Individual de 1 unidad	FD-1D2/ST (White) FD-1D2/ST (БЕЛЫЙ) FD-1D2/ST (BLANCO)
	LC flangeless connector PB sleeve, 19.20mm Individual Pack of 1 unit	Support Sleeve PB Connecteur LC, 19,20 mm Pack individuel de 1 unité	Manga de apoyo conector PB LC, 19.20mm Pack Individual de 1 unidad	FD-2D2/LC (White) FD-2D2/LC (БЕЛЫЙ) FD-2D2/LC (BLANCO)
	SC flangeless connector PB sleeve, 19.20mm Individual package: 1pc.	Support Sleeve PB Connecteur LC, 19,20 mm Pack individuel de 1 unité	Manga de apoyo conector PB SC, 19.20mm Pack Individual de 1 unidad	FD-2D2/SC (White) FD-2D2/SC (БЕЛЫЙ) FD-2D2/SC (BLANCO)

ACCESSORIES FOR MULTIMEDIA SOCKETS / ACCESSOIRES POUR CONNECTEURS MULTIMÉDIA / ACCESORIOS PARA CONECTORES MULTIMEDIA

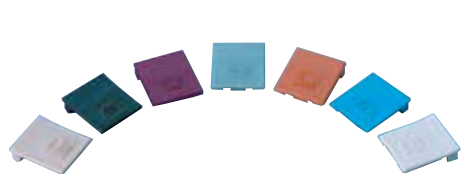

Shutters with
designation symbols
Package: 50 pcs

Casquettes avec des symboles
signalisation
Pack de 50 unités

Tapas con símbolos
de señalización
Pack de 50 unidades

FD-ICON-D-XX
FD-ICON-V-XX
FD-ICON-C-XX
FD-ICON-5e-XX
FD-ICON-N-XX
FD-ICON-6-XX

D – DATA (monitor/moniteur / monitor)
V – VOICE (telephone/téléphone / teléfono)
C – Cat. 5
5e – Cat. 5e
N – without marking
6e – Cat. 6

When ordering shutters it is necessary to add the appropriate color codes: beige (IV), white (WH), grey (GY), black (BK), red (RD), orange (OR), blue (BL), green (GN), yellow (YL)
Pour commander les couvertures, il est nécessaire d'indiquer les codes de couleurs appropriés: beige (IV), blanc (WH), gris (GY), noir (BK), rouge (RD), orange (O), bleu (BL), vert (GN), jaune (YL).
Para solicitar las tapas es necesario indicar los códigos de color apropiado: beige (IV), blanco (WH), gris (GY), negro (BK), rojo (RD), naranja (O), azul (BL), verde (GN), amarillo (YL).

	Plug Designed for closing the unused seat on the mounting plate Pack of 10 units	Connecteur Conçu pour la fermeture du module de montage sans utiliser Pack de 10 unités	Conector Diseñado para el cierre del módulo de montaje sin usar Pack de 10 unidades	FD-ISKWH
---	--	---	---	----------

OUTLETS FOR 6E CATEGORY INFORMATION NETWORKS / CATÉGORIES INFORMATIQUES 6 / TOMAS INFORMÁTICAS CATEGORÍA 6

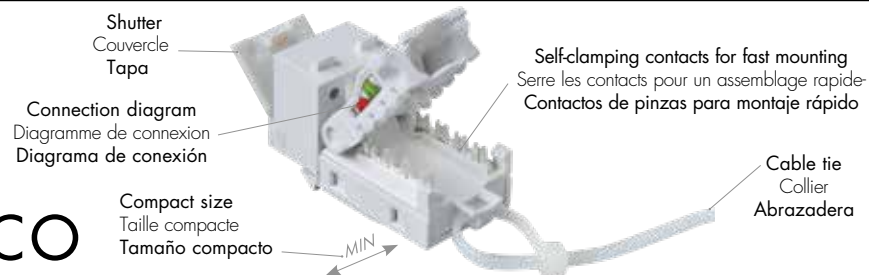

Bronze gold-plated contacts
Contacts recouverts d'or et de bronze
Contactos recubiertos de oro y bronce

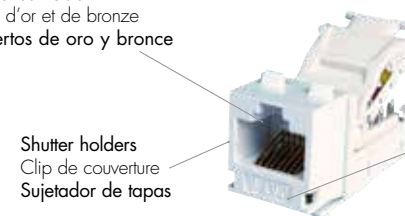

Category designation
Désignation de catégorie
Designación de categoría

MARCO
COLLECTION

Devices to increase comfort



Thermostat with Metal Cover

FEDE+ presents a wide range of electronic devices to provide you with a more comfortable lifestyle. Thermostats for air temperature control, under floor heating and new multi-function thermostat.



*ITEMS' REAL SIZE ARE SHOWN IN THE IMAGES

For those who prefer original finishes made in brass in perfect combination with our covers, FEDE has developed a new version of our technologically advanced electronic thermostats.

THERMOSTATS / THERMOSTATS / TERMOSTATI / THERMOSTATOS / THERMOSTATE



Thermostat for electrical heating floors control 16A 230V ± 10%, 50/60 Hz.
 Temperature control range: 5-45°C
 Cable 4m with sensor for electrical heating floors included in package
 Thermostat pour le contrôle électrique des planchers chauffants 16A 230V 10%,
 50/60 Hz. Plage de contrôle de la température: 5-45°C
 Câble 4m avec capteur pour contrôle électrique des planchers chauffants inclu
 dans le prix
 Termostato per controllo di riscaldamento di pavimenti 16A 230V ± 10%,
 50/60 Hz. Gamma di temperatura: 5-45°C
 Cavo di 4m. con sensore per riscaldamento pavimenti incluso nel prezzo
 Termostato para suelos radiantes 16A 230V ± 10%, 50/60 Hz
 Rango del control de temperatura: 5-45°C
 Cable de 4m. con sensor de suelo radiante eléctrico incluido en el paquete.
 Thermostat für Steuerung von elektrischer Bodenheizung 16A 230V ± 10%,
 50/60 Hz. Temperaturregelbereich: 5-45°C
 Kabel 4m. mit Sensor für elektrische Fussbodenheizung im Lieferumfang enthalten

COLORS OF BRASS FRONT COVERS / COLORS OF PLASTIC SUPPORTS AND BUTTONS
 COULEURS DES COUVERTURES EN LAITON / COULEURS DES SUPPORTS EN PLASTIQUES ET DES BOUTONS
 COLORI DELLE COVERS IN OTTONE / COLORI DEI SUPPORTI IN PLASTICA E DEI PULSANTI
 COLORS OF BRASS FRONT COVERS / COLORS OF PLASTIC SUPPORTS AND BUTTONS
 FARBEN DER MESSING-FRONTABDECKUNGEN / FARBEN DER KUNSTSTOFFHALTER UND SCHALTFLÄCHEN

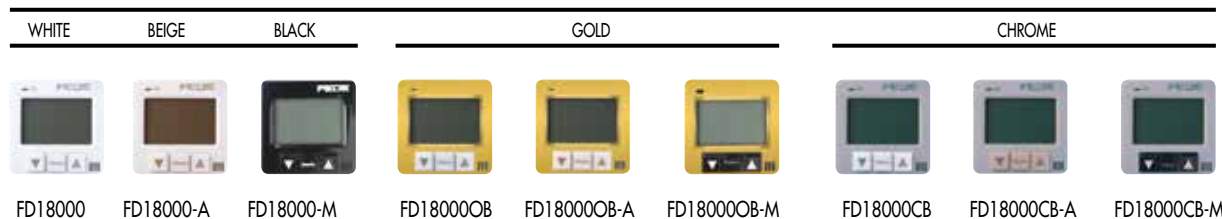

Thermostat for room temperature control 16A 230V ± 10%, 50/60 Hz,
 Temperature control range: 5-45°C
 Thermostat pour la régulation de la température ambiante 16A 230V 10% 50/60 Hz,
 Plage de contrôle de la température: 5-45°C
 Termostato per il controllo della temperatura ambiente 16A 230V 10% 50/60 Hz
 Gamma di temperatura: 5-45°C
 Para control de temperatura de habitación 16A 230V ± 10%, 50/60 Hz,
 Temperature control range: 5-45°C
 Thermostat für Raumtemperaturregelung 16A 230V ± 10%, 50/60 Hz



Multi-function Thermostat
 Thermostat multifonction
 Termostato multifunzione
 Termostato multifunción
 Multi-Funktions-Thermostat

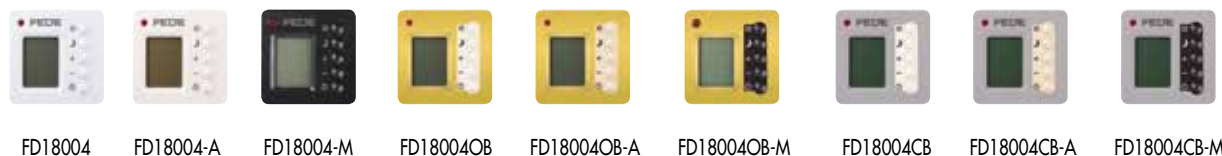

* Thermostats can be installed in 1 gang frame only
 * Les thermostats peuvent être installés uniquement avec un module dans les plaques
 * I termostati possono essere installati unicamente nelle scocche da 1 modulo

* Los termostatos sólo se pueden instalar en marcos de 1
 * Thermostate können nur in 1er Rahmen installiert werden

NOTE: Fixing installation supports are included in all models
 NOTE: Les supports de fixation sont inclus pour tous les modèles
 NOTA: I telai fissativi sono inclusi in tutti i modelli
 NOTA: Los bastidores están incluidos en todos los modelos
 HINWEIS: Träger für Befestigung Installation sind in allen Modellen enthalten

New Cord Outlets



NEW CORD OUTLETS / SORTIE DE CÂBLE / SALIDA DE CABLE

With fixing clamp up to
Ø8mm.

С фиксатором для кабелей
Ø8mm в комплекте.

Con brida de sujeción de hasta
Ø 8 mm.

WHITE

BEIGE

BLACK



FD18034

FD18034-A

FD18034-M

Pack of 10 units / Pack de 10 unités / Pack de 10 unidades

New Brass Blank Plates



NEW BRASS BLANK PLATES / NUEVAS TAPAS CIEGAS DE LATÓN

GOLD



FD04319OB

CHROME



FD04319CB

NEW PLASTIC BLANK PLATES / NUEVAS TAPAS CIEGAS DE PLÁSTICO

WHITE



FD17033

BEIGE



FD17033-A

BLACK



FD17033-M

Pack of 10 units / Pack de 10 unités / Pack de 10 unidades

MARCO
COLLECTION



FD17-BAST

Polyamide support for fixing mechanisms.
Pack of 1 unit.

Support de fixation en polyamide pour les mécanismes.
Pack de 1 unité.

Basidor de poliamida reforzado con fibra de vidrio para la fijación de mecanismos.
Pack de 1 unidad.

Polyamid-Halter für Mechanismusbefestigung
Enheitige Verpackung

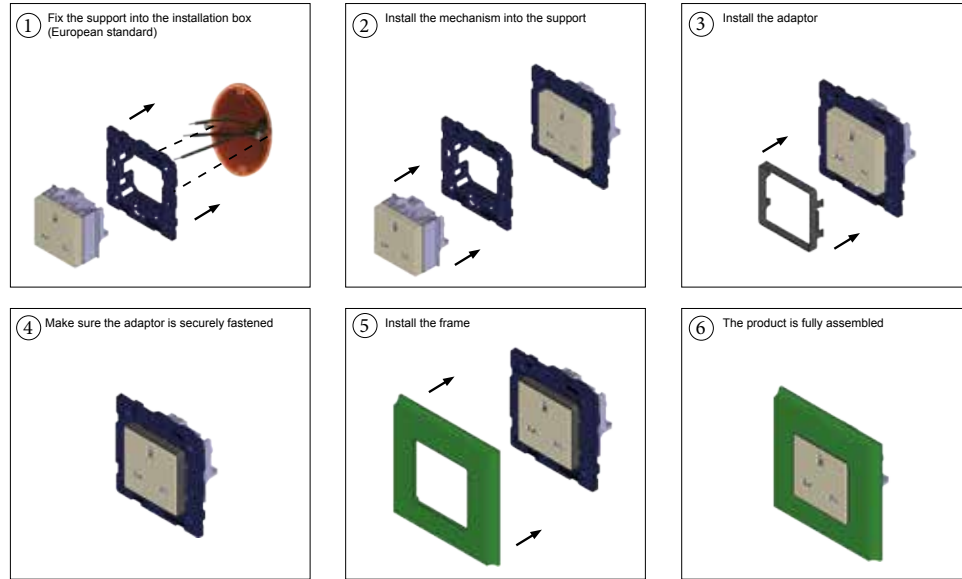

INSTALLATION ACCESSORIES

SQUARE INSTALLATION BOX FOR CONCRETE/BRICK WALLS. Joinable
CAISSE STANDARD CARRÉE. Joignable.
CASSA QUADRATA STANDARD. Montabile
CAJA CUADRADA ESTÁNDAR. Acoplable.
VIERECKIGE STANDARDBOX. Für Hohlwände.



FD2373
71 x 71 x 43 mm

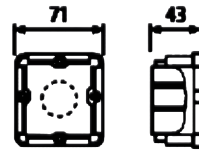

FD2374-I

Tapa protección
Permite localizar las
cajas después de enlucir



FD316
75 x 75 x 42 mm

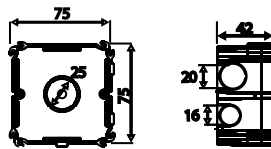

FD318
75 x 75 x 60 mm

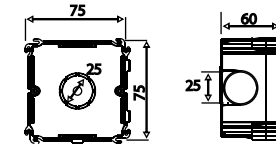

UNIVERSAL COVER (SPECIALLY FOR BOXES: FD404, FD406, FD407)
COUVERTURE UNIVERSELLE (ESPECIAL POUR: FD404, FD406, FD407)
COVERS UNIVERSALE (SPECIALMENTE PER: FD404, FD406, FD407)
TAPA UNIVERSAL (EN ESPECIAL PARA: FD404, FD406, FD407)
UNIVERSELLE ABDECKUNG (SPEZIELL FÜR DIE PACKUNGEN: FD404, FD406, FD407)



FD501001
Ø 60 mm

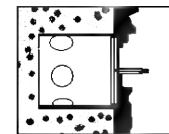
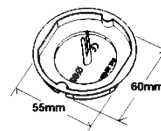

*To protect the boxes against the ingress of cement during the finishing works.
*Pour protéger les boîtes contre la pénétration de ciment durant les travaux de finition.
*Per proteggere le casse contro la penetrazione di cemento durante i lavori di finitura.
*Para proteger las cajas contra la entrada de cemento durante los trabajos de acabado.
*Um die Packungen vor dem Eindringen von Zement während der Ausbaurbeiten zu schützen.

FOR HOLLOW WALLS
POUR LES MURS CREUX
PER PARETI CONCAVE
APTA PARA PLADUR
FÜR HOHLWÄNDE

Switch Box Group/Boîte pour Appareillage Jumelable/Cassa per meccanismi montabili/Caja para Mecanismos Enlazable/Schaltkastengruppe

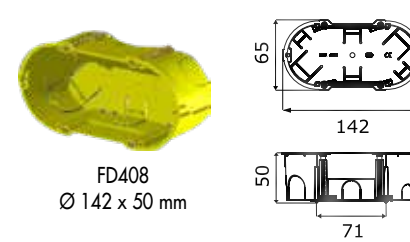
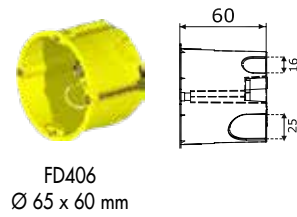
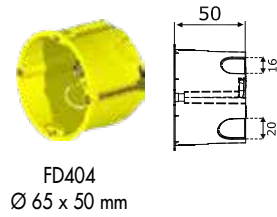
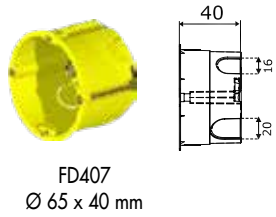

ROUND INSTALLATION BOX FOR CONCRETE/BRICK WALLS. Joinable
CAISSE STANDARD RONDE. Joignable.
CASSA ROTONDA STANDARD. Montabile.
CAJA REDONDA ESTÁNDAR. Acoplable.
RUNDE STANDARDBOX. Für Hohlwände.



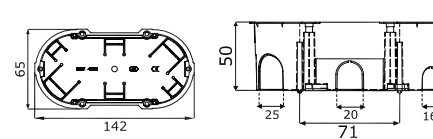
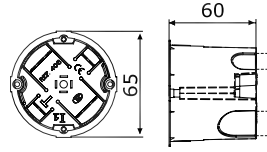
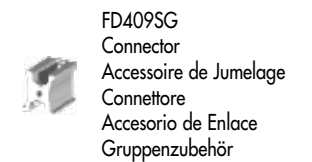
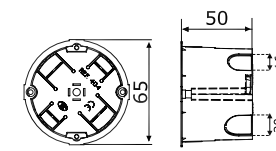
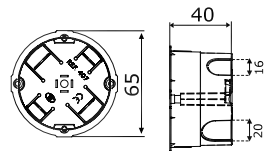
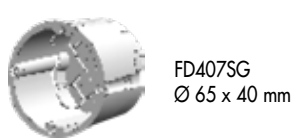

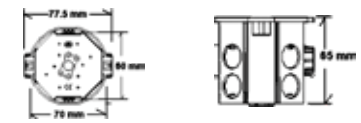
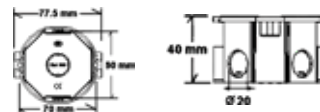

Switch Box Group/Boîte pour Appareillage Jumelable/Covers del meccanismo montabile/Caja para Mecanismos Enlazable/Schaltkastengruppe



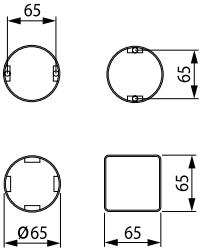

Switch box. Joinable/Boîte d'appareillage encastrable dans les parois en béton/Covers del meccanismo montabile/Caja de mecanismos de profundidad/Unterputzdose

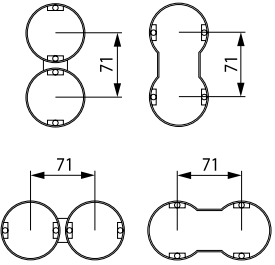
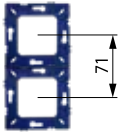
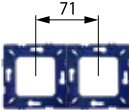

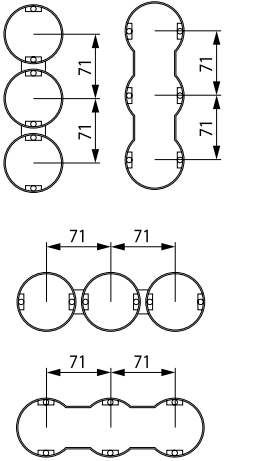
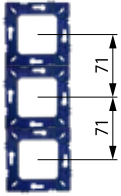
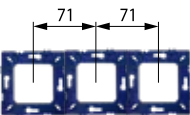

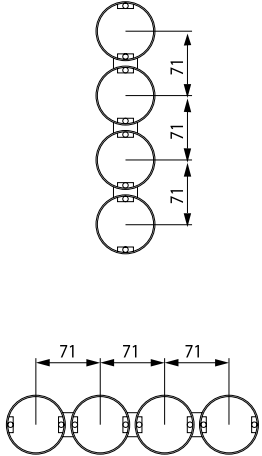
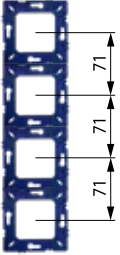
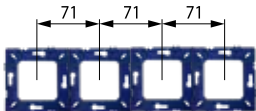

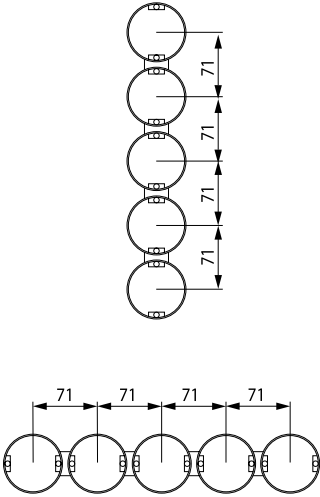
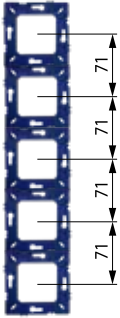
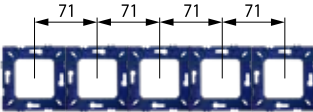























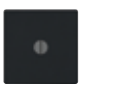

















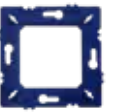

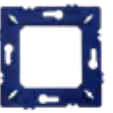

INSTALLATION EXAMPLES

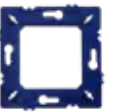
COMPOSITION	BOX	FIXING SUPPORT
 <p>1 MODULE</p>		 
 <p>2 MODULES</p>		 
 <p>3 MODULES</p>		 

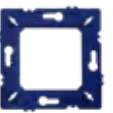
COMPOSITION	BOX	FIXING SUPPORT
 <p>4 MODULES</p>		 
 <p>5 MODULES</p>		 

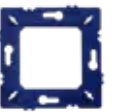
COMPOSITION OF MOST USUAL ITEMS

DESCRIPTION	FRAME	MECHANISMS	TOGGLE /COVER/ HANDLE	LIGHT INDICATOR	BRASS COVER	FIXING SUPPORT
NEW 1 TOGGLE SWITCH	FD01601BK 	FD16505 	FD02317OB-M 		FD04320OB-M 	FD17-BAST 
NEW 2 TOGGLE SWITCHES	FD01601BK 	FD16505 x 2 	FD02317T-M x 2 	FD21139-1 	FD04321OB-M 	FD17-BAST 
1 WIDE KEY SWITCH	FD01601BK 	FD16505 	FD04310OB 			FD17-BAST 
NARROW KEY SWITCH	FD01601BK 	FD16505 x2 	FD04313OB x2 	FD21139-2 		FD17-BAST 
ROTARY SWITCH	FD01601BK 	FD03110-M 	FD02310OB 			FD17-BAST 
ROTARY DIMMER	FD01601BK 	FD16438-M 	FD04336OB  *OPTIONAL ITEM			FD17-BAST 
BRASS ROTARY DIMMER	FD01601BK 	FD016438CB 	FD04336OB  *OPTIONAL ITEM			FD17-BAST 
TOUCH DIMMER	FD01601BK 	FD28625-M 				FD17-BAST 

DESCRIPTION	FRAME	MECHANISMS	SOCKET COVER	FIXING SUPPORT
GERMAN SOCKET	FD01601BK 	FD16823 	FD04335OB 	FD17-BAST 
FRENCH SOCKET	FD01601BK 	FD16623 	FD04324OB 	FD17-BAST 
BRITISH SOCKET	FD01601BK 		FD20000B 	FD17-BAST 
AMERICAN SOCKET	FD01601BK 		FD22000OB 	FD17-BAST 
EURO AMERICAN SOCKET	FD01601BK 		FD21000OB 	FD17-BAST 
USB CHARGER DOUBLE OUTPUT PORT	FD01601BK 		FD-21 2USBOB-A 	FD17-BAST 

DESIGNATION OF COLORS IN CODES

FDXXXX

Non-lettered codes are used for white items.

FDXXXXAA

The letters at the end of the codes indicate the color of the item.

FDXXXXAA-B

The letters after the dash indicate the color of the plastic base in articles with brass covers.

Color designations:

- A** — BEIGE
- M** — BLACK
- OB** — GOLD
- CB** — CHROME

Example:

FD04335OB-A — Socket cover

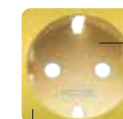

Plastic socket color = «A» — BEIGE

Brass cover color = «OB» — GOLD

CONNECTION DIAGRAMS OF SWITCHES AND PUSH BUTTONS

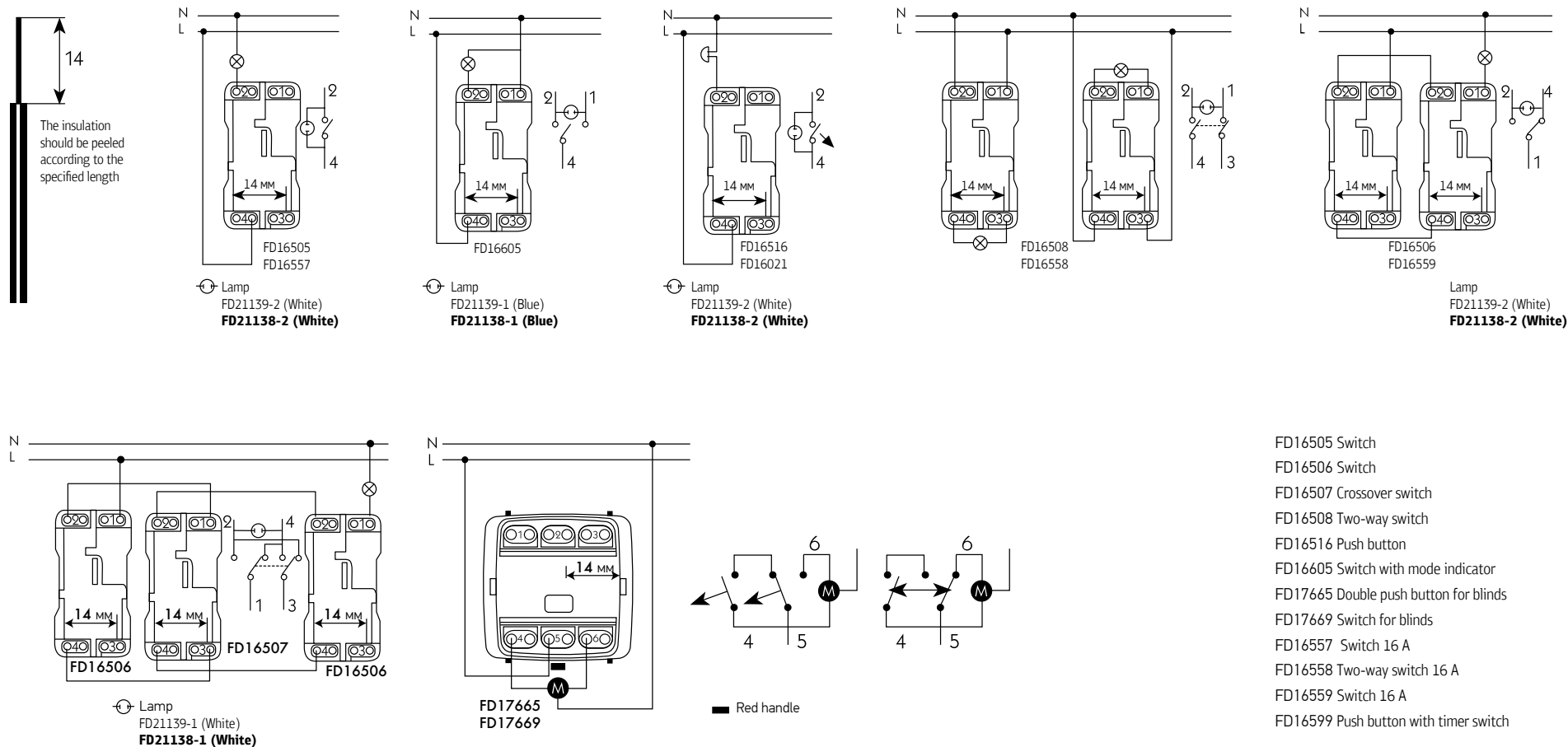

- FD16505 Switch
- FD16506 Switch
- FD16507 Crossover switch
- FD16508 Two-way switch
- FD16516 Push button
- FD16605 Switch with mode indicator
- FD17665 Double push button for blinds
- FD17669 Switch for blinds
- FD16557 Switch 16 A
- FD16558 Two-way switch 16 A
- FD16559 Switch 16 A
- FD16599 Push button with timer switch

WARNING:

1. The codes of the diffuser lamps for the handle switches are indicated in **bold**.
2. When using the switches with diffuser for the control of low-energy lamps, the resistor FD3139 must be installed.

CONNECTION DIAGRAMS OF ROTARY SWITCHES

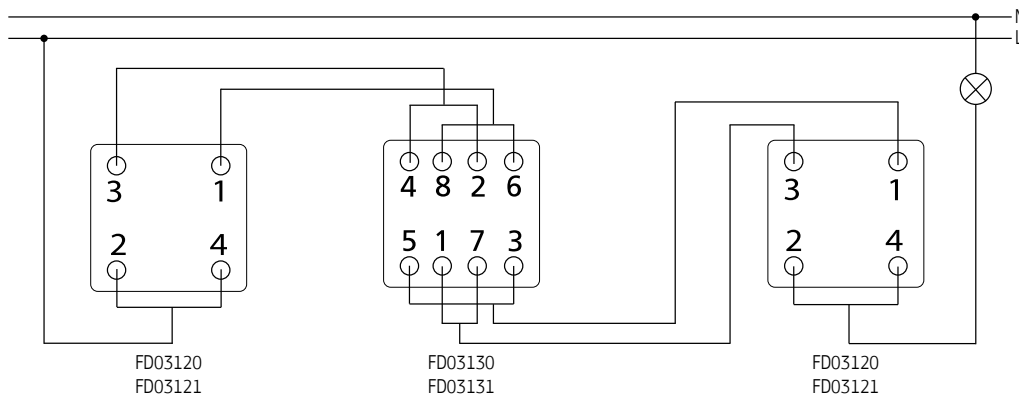
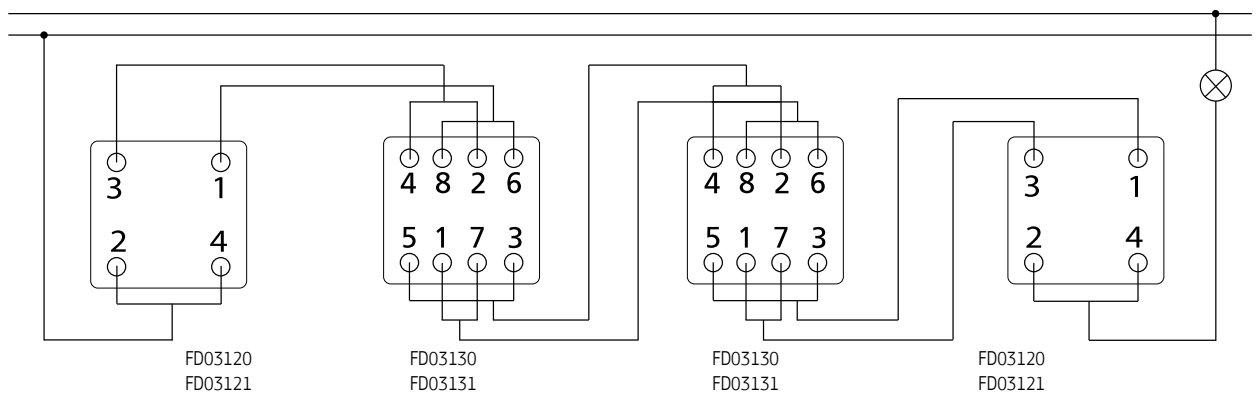
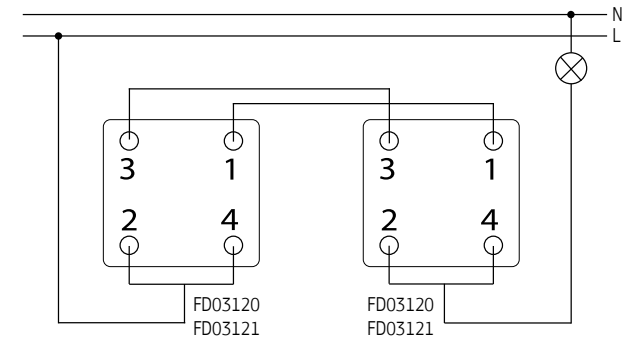
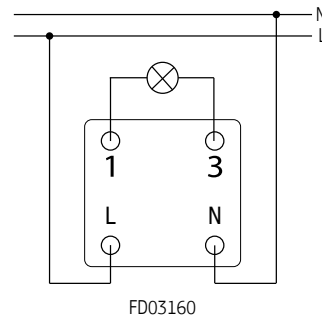
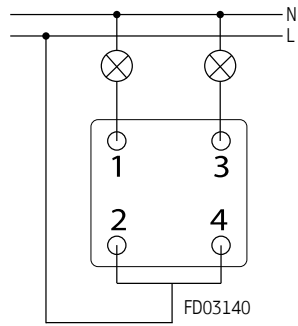
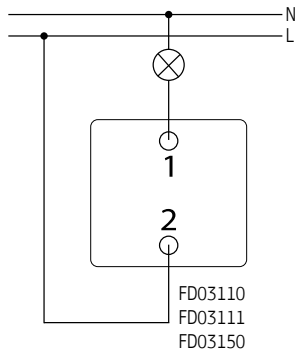

- FD03110 / FD03111** One-way rotary switch 10 A / One-way rotary switch 10 A for LED
- FD03120 / FD03121** Two-way rotary switch / Two-way rotary switch for LED
- FD03130 / FD03131** Intermediate rotary switch / Intermediate rotary switch for LED
- FD03140** Double one-way SP switch
- FD03150** One-way rotary switch 25 A
- FD03160** Double pole rotary switch 25 A

CONNECTION DIAGRAMS OF TOUCH SWITCHES

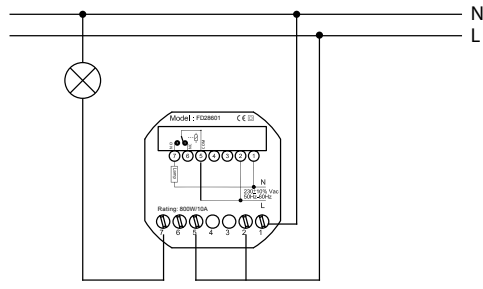

FD28601

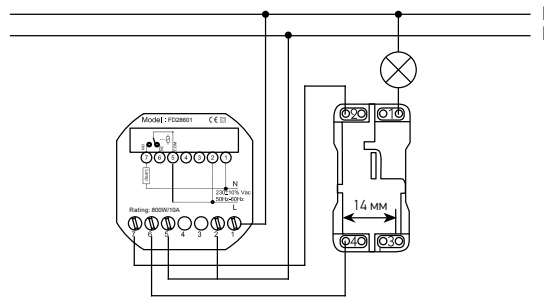

FD28601

FD16506

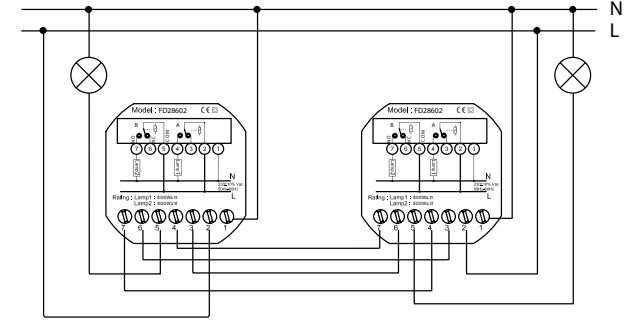

FD28602

FD28602

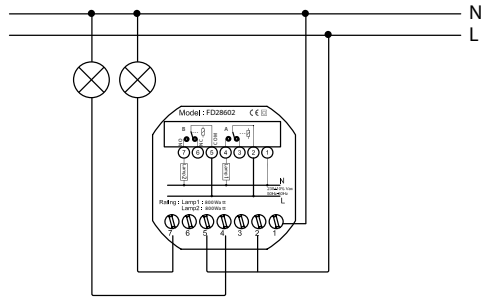

FD28602

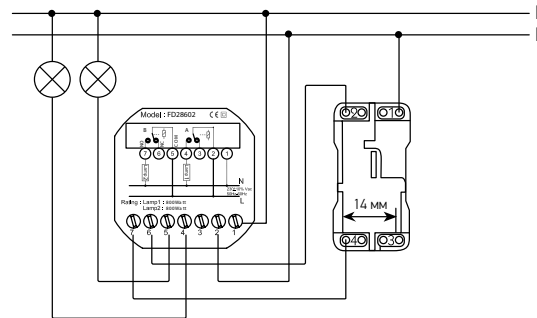

FD28602

FD16506

Using 1 channel

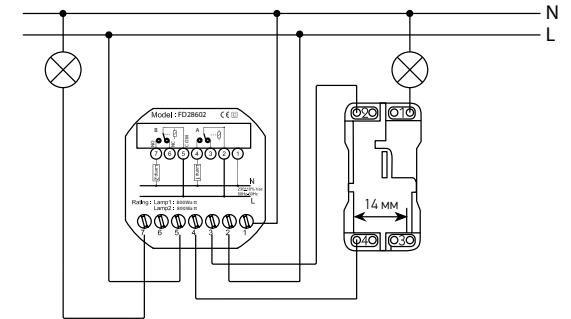

FD28602

FD16506

Using 2 channels

- FD28601** Individual-light switch
- FD28602** Double-key -light switch
- FD16506** Two-way SP switch

Bathroom light switch FD28603

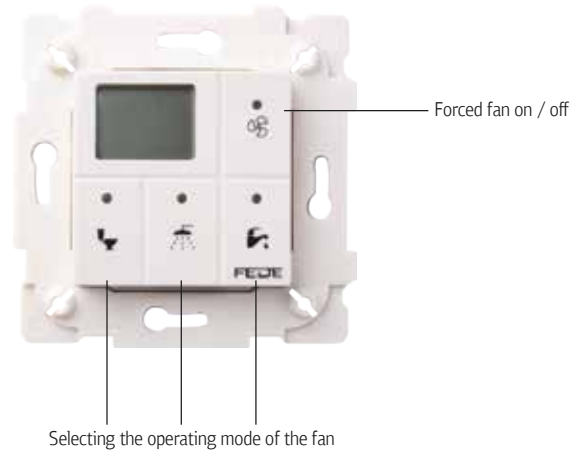

Includes both lighting and ventilation. When leaving the room, depending on the option of using the bathroom, the user presses the key with the corresponding symbol and the lighting goes out, while the ventilation continues to operate for a predetermined time. There is also the possibility to turn the fan on / off manually. The current setting and the operating mode are displayed on the LCD.

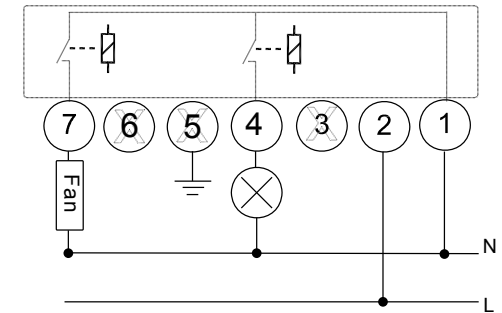

Infrared light switch FD28604

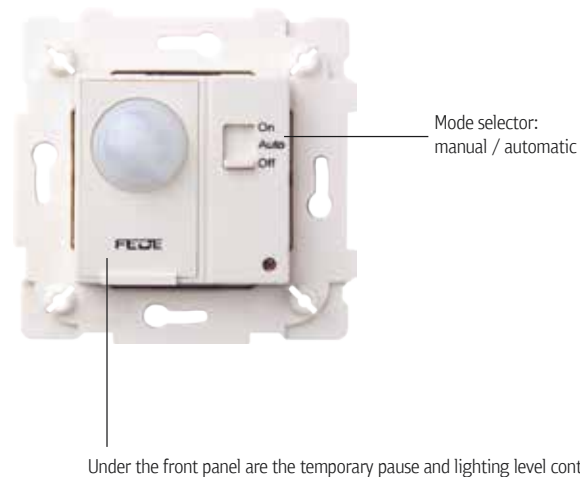

The presence detector switch allows devices to be activated automatically when a person is approaching (for example, lighting). To optimize the characteristics you can adjust the level of illumination, with which the device will be activated, as well as the duration of its operation. In addition, on the front of the device is a switch, which allows to force its activation or deactivation manually.

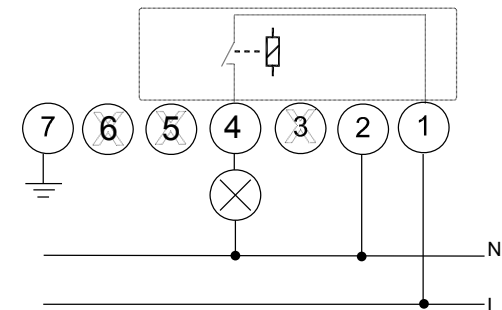

CONNECTION DIAGRAMS FOR DIMMERS

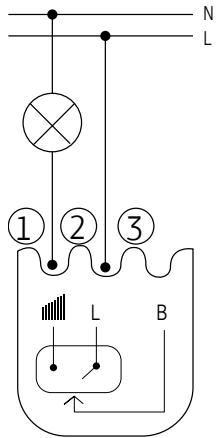

FD28625

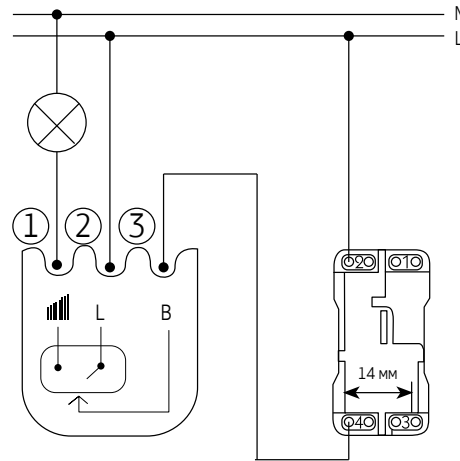

FD28625

FD16505

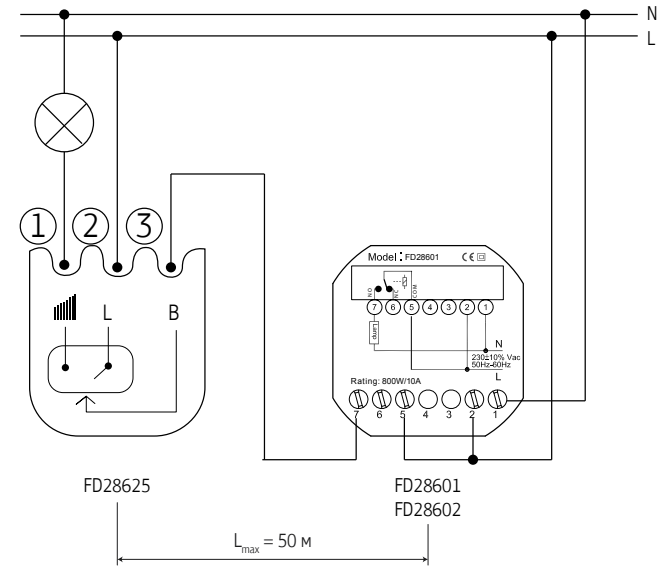

FD28625

FD28601
FD28602

$L_{max} = 50\text{ m}$

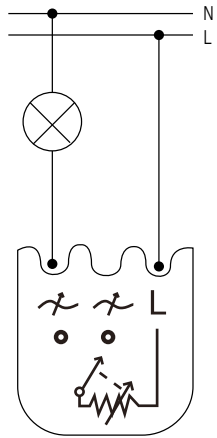

FD16438

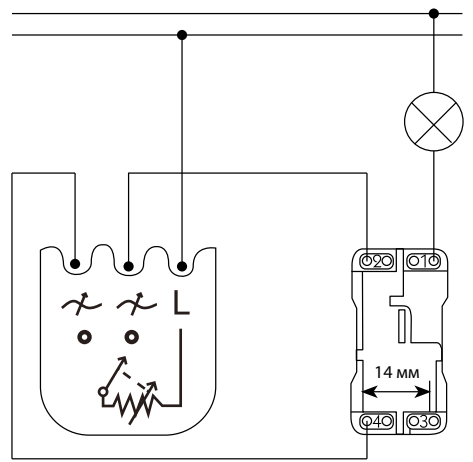

FD16438

FD16506

- FD16505** One-way SP switch
- FD16506** Two-way SP switch
- FD16438** Rotary dimmer
- FD28601** Individual-light switch
- FD28602** Double-key light switch
- FD28625** Compact touch dimmer for all FEDE frames collections

DIAGRAMS OF CONNECTION FOR DIMMERS FOR PUSH BUTTONS

To control the light regulators use the mechanisms of the push buttons FD16516 without LED.

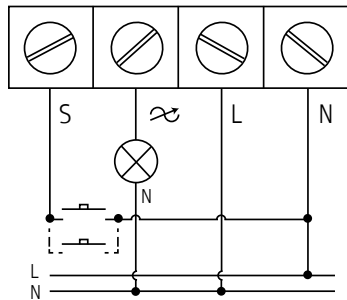

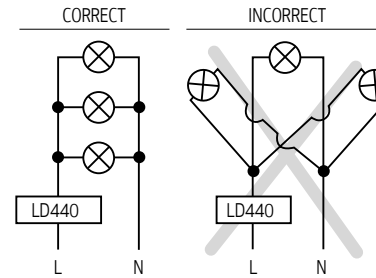

Load connection:

To reduce the level of electromagnetic interference, use a parallel connection of the load circuit.



- LD220** Dimmer for push button installation
- LD440** Dimmer for push button installation
- LD220WCM** Dimmer for push button installation
- LD220KRON** Dimmer for push button installation

TABLE FOR SELECTION OF DIMMERS

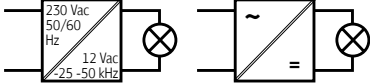
Code	Dimmer type			
		For incandescent and halogen lamps	For dimmable CFLs and LEDs with E14, E27 and GU10 base	For dimmable electronic transformers and LED drivers
FD16438	Rotary	750 W	No	No
FD28625	Touch	600 W	No	No
LD220	To install with push button	200 W	200 W	200 W
LD440	To install with push button	440 W	440 W	440 W
LD220WCM	To install with push button	200 W	200 W	200 W
LD220KRON	To install with push button	2×100 W	2×100 W	2×100 W

THERMOSTAT CONNECTION DIAGRAMS

Thermostats FD18000/FD18001

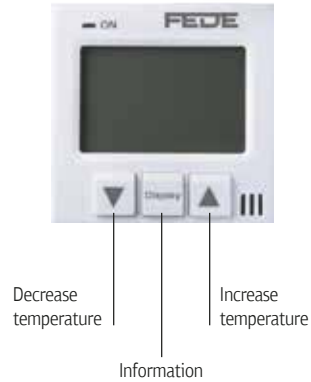

This thermostat provides simple and intuitive temperature management, whose current settings are displayed on a large LCD. Thanks to the built-in RGB, the thermostat display changes color according to the operating mode: when the heating mode is activated, the display will light blue. The set temperature and the actual temperature are shown alternately on the display; pressing the "DISPLAY" button will only display the actual temperature, and pressing the button again will re-activate the information collation mode.

There are two versions of thermostat available:

FD18000 — to control the floor temperature.

FD18001 — to control the room air temperature.

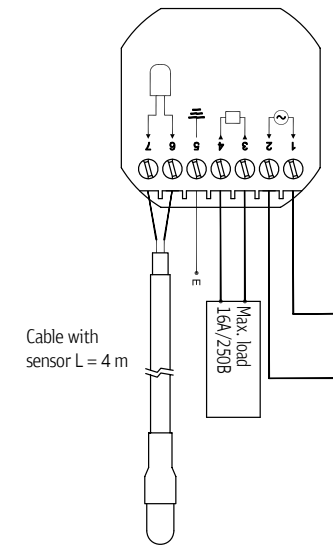

Multifunctional thermostat FD18004

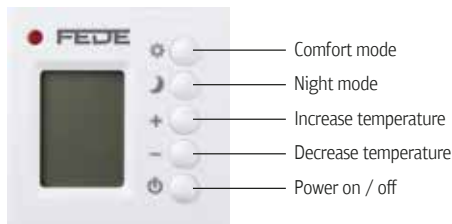

This thermostat allows the previous programming of two modes of operation: economic and comfort. The modes are selected by clicking on corresponding buttons. The LCD displays the current thermostat setting.

This thermostat can operate in the following modes:

- floor temperature control.
- air temperature control.
(for example, when connecting electric radiators)
- combined mode

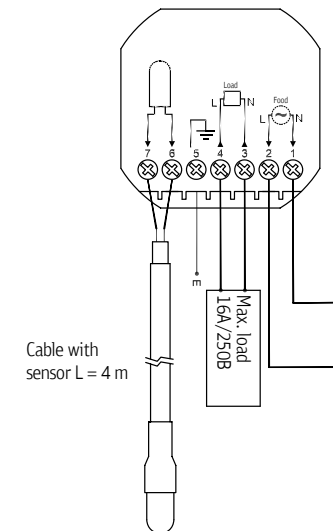

MECHANISM CONNECTION DIAGRAMS FOR POWER TV SOCKET OUTLETS

There are two types of television signal wiring for several users: the parallel circuit ("star" wiring) and the series circuit.

In the first case the dividers, also called separators, are used, which are responsible for equitably dividing the power of the input signal into 2, 3 and 4; although it should be noted that for each division in 2 the power of the signal for each output also decreases by half (actually even a little more: the signal drop is usually 3.5-4.5 dB). This method of wiring provides a great uniformity of power in the television frequency band and a great insulation between the terminals, however, it requires more cables.

In the second case the couplers are used and the television channels are connected in series (cascade) one after another. This type of wiring offers unequal division of the signal. Such a wiring method provides uneven division of the signal, is easier to implement and requires fewer cables. However, when this scheme is implemented the signal reaches a lower number of TV receivers.

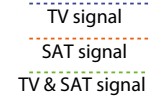

EXAMPLE OF USING THE FD220F PLUG BASE TO CREATE A "WATERFALL" TV / SATELLITE NETWORK WITH AN IF-IF CABLE

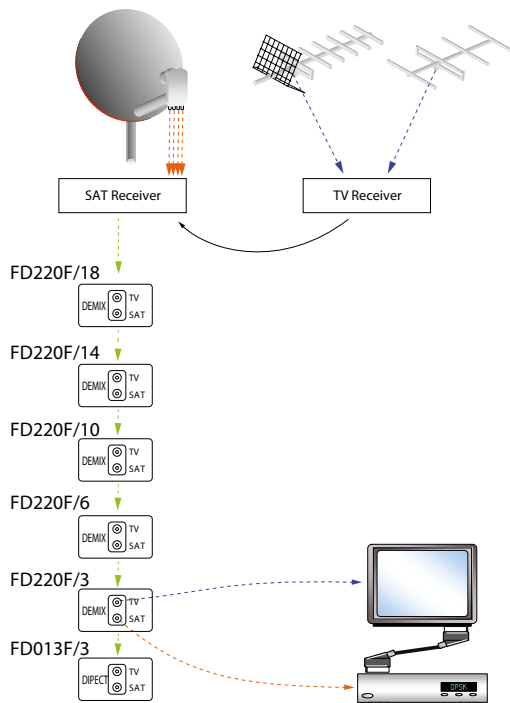

EXAMPLE OF USE OF FD010F PLUG BASES TO CREATE A "STAR" TYPE TV / SATELLITE NETWORK

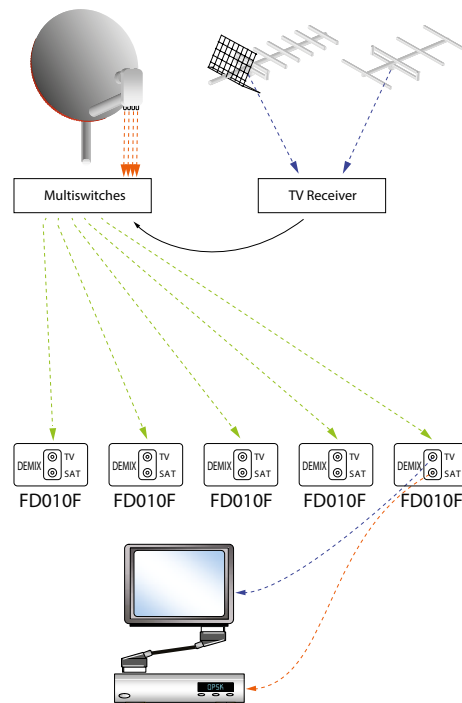

EXAMPLE OF USE FD011F SOCKET OR "ECOCOMPACT" KIT TO CREATE THE TV / SATELLITE NETWORK

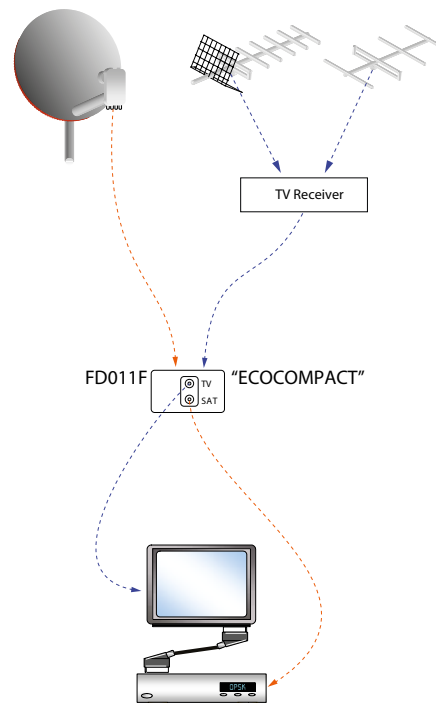

EXAMPLE OF USE FD506F AND FD002F SOCKETS TO ESTABLISH A "WATERFALL" TV NETWORK AND THE DIRECT CONNECTION OF TV SATELLITE

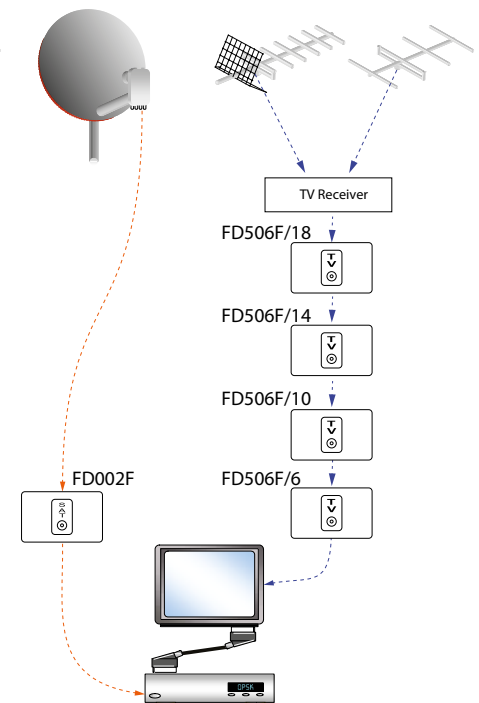

We reserve the right to carry out modifications on our models, sizes, finishes and on the information contained in the present CATALOGUE without prior notice. Copying this CATALOGUE is expressly forbidden without our consent.

Nous nous réservons le droit de réaliser des changements dans nos modèles, nos tailles, nos finitions et dans les formations contenues dans le CATALOGUE ci-présent sans avis préalable. La copie de ce CATALOGUE est formellement interdite sans notre accord préalable.

Ci riserviamo il diritto di apportare cambiamenti nei nostri modelli, dimensioni, finiture e le informazioni contenute in questo CATALOGO senza preavviso. Copiare questo catalogo è espressamente proibito senza il nostro consenso.

Nos reservamos el derecho a realizar modificaciones en nuestros modelos, tamaños, acabados y sobre la información contenida en el presente CATÁLOGO sin previo aviso. La copia de este catálogo está expresamente prohibida sin nuestro consentimiento.

Wir behalten uns das Recht Änderungen vorzunehmen in unseren Modellen, Größen, Ausführungen und die Informationen in diesem Katalog ohne vorherige Ankündigung. Die Kopie dieses Katalogs ist ohne unsere Zustimmung nicht gestattet.



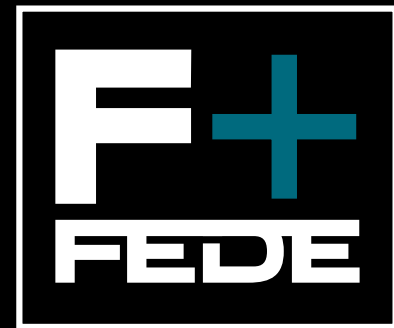

MARCO
COLLECTION

HEADQUARTERS & SHOWROOM

Av. Llenguadoc, 45-47 · (08915) Badalona · (Barcelona) SPAIN · Phone +34 934 183 856 · info@fedepius.com

www.fedepius.com

C2018 #001